

NF120 (-S) US

On-off, Spring Return Fail-Safe, 120 VAC



Torque min. 60 in-lb, for control of air dampers

Application

For on-off, fail-safe control of dampers in HVAC systems. Actuator sizing should be done in accordance with the damper manufacturer's specifications. Control is on-off from an auxiliary contact, or a manual switch.

The actuator is mounted directly to a damper shaft up to 1.05" in diameter by means of its universal clamp. A crank arm and several mounting brackets are available for applications where the actuator cannot be direct coupled to the damper shaft.

Operation

The NF series actuators provide true spring return operation for reliable fail-safe application and positive close off on air tight dampers. The spring return system provides constant torque to the damper with, and without, power applied to the actuator.

The NF series provides 95° of rotation and is provided with a graduated position indicator showing 0° to 95°. The actuator may be stalled anywhere in its normal rotation without the need of mechanical end switches.

The NF120-S US versions are provided with 1 built-in auxiliary switch. This SPDT switch is provided for safety interfacing or signaling, for example, for fan start-up. The switching function is adjustable between 5° and 85°.

Technical Data	NF120 (-S) US
Power supply	120 VAC ± 10% 50/60 Hz
Power consumption	running: 6 W; holding: 3.5 W
Transformer sizing	7 VA
Electrical connection	3 ft, 18 GA appliance cable 1/2" conduit connector
Overload protection	Electronic throughout 0 to 95° rotation
Electrical protection	Auxiliary switches are double insulated
Angle of rotation	95°, adjustable 30 to 95° w/ accessories
Torque	60 in-lb [7 Nm] constant torque
Direction of rotation	reversible with CW/CCW mounting
Position indication	visual indicator, 0° to 95° (0° is spring return position)
Auxiliary switches (-S models)	1 x SPDT 7A (2.5A) @ 250 VAC, UL listed, adjustable 5° to 85°
Running time (nominal)	motor: < 75 sec spring: < 60 sec
Humidity	5 to 95% RH non-condensing
Ambient temperature	-22°F to +122°F [-30°C to +50°C]
Storage temperature	-40°F to +176°F [-40°C to +80°C]
Housing	NEMA type 2 / IP54
Housing material	zinc coated steel
Agency listings	UL 873 listed, CSA C22.2 No.24 certified
Noise level	max. 45 dB (A)
Servicing	maintenance free
Quality standard	ISO 9001
Weight	7.3 lbs (3.3 kg.)

Dimensions [All numbers in brackets are in millimeters.]

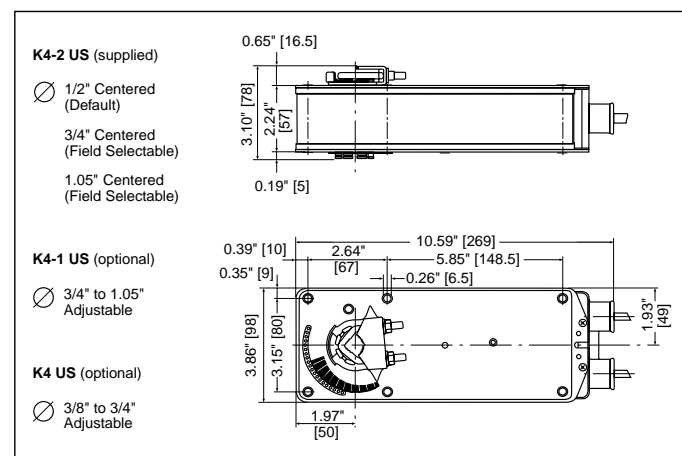

Accessories

AV 10-18	Shaft extension
IND-AF2	Damper position indicator
K4-1 US	Universal clamp for up to 1.05" dia jackshafts
K4-H	Universal clamp for hexshafts 3/8" to 5/8"
KH-AF	Crankarm for up to 3/4" round shaft
KH-AF-1	Crankarm for up to 1.05" jackshaft
KH-AFV	V-bolt kit for KH-AF and KH-AF-1
Tool-06	8mm and 10 mm wrench
ZG-HTR	Thermostat/Heater Kit
ZDB-AF2	Angle of rotation limiter
ZG-100	Universal mounting bracket
ZG-101	Universal mounting bracket
ZG-102	Multiple actuator mounting bracket
ZG-103	Universal mounting bracket
ZG-104	Universal mounting bracket
ZG-106	Mounting bracket for Honeywell® Mod IV replacement or new crankarm type installations
ZG-107	Mounting bracket for Honeywell® Mod III or Johnson® Series 100 replacement or new crankarm type installations
ZG-108	Mounting bracket for Barber Colman® MA 3../4.., Honeywell® Mod III or IV or Johnson® Series 100 replacement or new crankarm type installations
ZG-AF US	Crankarm adaptor kit for AF/NF
ZG-AF108	Crankarm adaptor kit for AF/NF
ZS-100	Weather shield (metal)
ZS-150	Weather shield (polycarbonate)
ZS-260	Explosion-proof housing
ZS-300	NEMA 4X housing

Note: When using NF120 US and NF120-S actuators, only use accessories listed on this page.

For Actuator Wiring Information and Diagrams, Please See Belimo Wiring Guide (pg 317).

Wiring diagrams

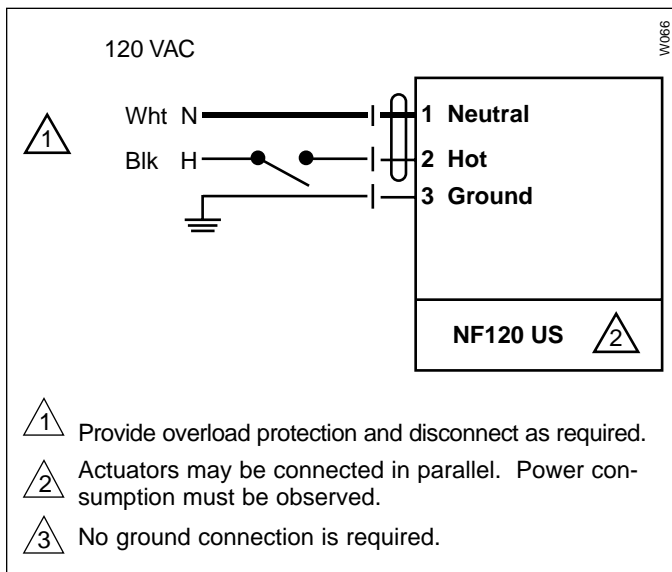

On-off wiring for NF120 US

NF120 US Typical Specification

On-off spring return damper actuators shall be direct coupled type which require no crankarm and linkage and be capable of direct mounting to a jackshaft up to a 1.05" diameter. The actuators must be designed so that they may be used for either clockwise or counterclockwise fail-safe operation. Actuators shall be protected from overload at all angles of rotation. If required, 1 SPDT auxiliary switch shall be provided having the capability of being adjustable. Actuators with auxiliary switches must be constructed to meet the requirements for Double Insulation so an electrical ground is not required to meet agency listings. Actuators shall be UL listed and CSA certified, have a 5 year warranty, and be manufactured under ISO 9001 International Quality Control Standards. Actuators shall be as manufactured by Belimo.

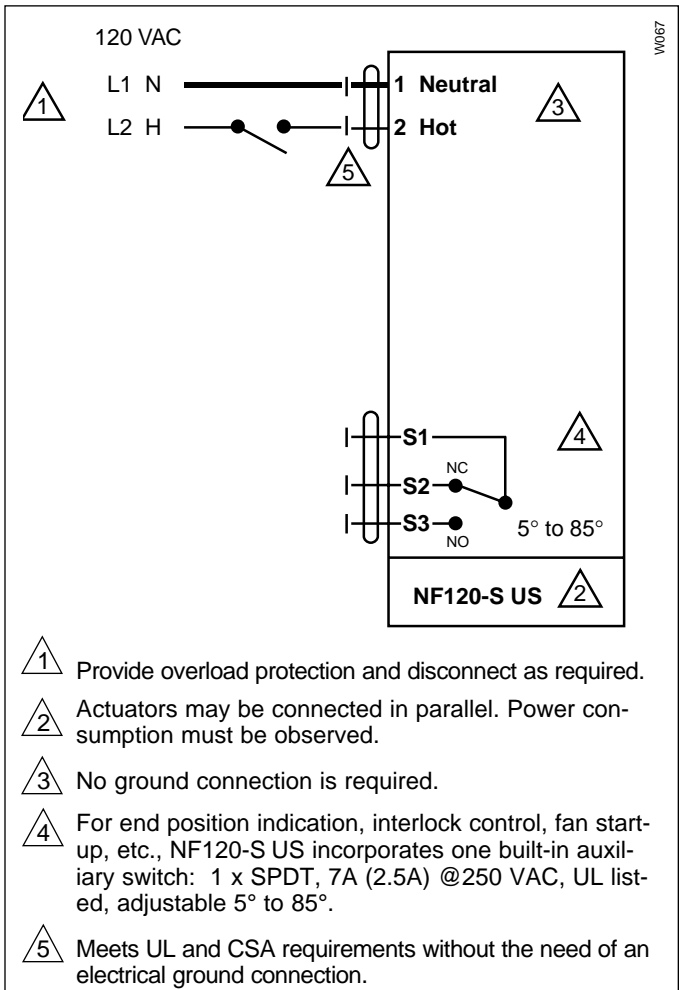

On-off wiring for NF120-S US