

Aluminum Damper

AD1/AD2

5" Deep • Single Thickness Blade

STANDARD CONSTRUCTION

- FRAME:** 5" x .081" extruded aluminum, hat shaped channel with reinforcing bosses and groove inserts for silicone seals
- BLADES:** 6" x .125" extruded aluminum, single unit pin-lock design, with the pin-lock at integral section within the blade core
- AXLES:** 1/2" dia. extruded aluminum, pin-lock design interlocking into blade section
- BEARINGS:** Double-Sealed type with celcon inner bearing on rod riding in polycarbonate outer bearing inserted in frame so that outer bearing cannot rotate
- LINKAGE:** Non-Corrosive reinforced metal or plated steel
- SEALS:** Extruded silicone seals fit into dovetail shaped slots on both frames and blades
- FINISH:** Mill

OPTIONS

- Hand Quadrants
- 120V, 24V, or Pneumatic Actuators
- Jackshafting
- Auxillary Switch
- Explosion Proof Housing

NOTES

1. "A" width and "B" height are opening dimensions. Dampers are provided approximately 1/4" undersize.
2. Dampers with multiple panels in both width and height may require structural support. It is recommended that large openings be designed with structural members so that dampers will span either width or height with a single panel. ABI does not supply structural support with standard dampers.
3. Dampers more than one panel wide or high and operated with one actuator must be jackshafted. Factory supplied actuators are shipped loose to be mounted external as standard.
4. Not recommended for blades installed vertically.
5. Approximate damper weight is 6.5 lbs./sq.ft.

DAMPER SIZE

Panels	Minimum Panel	Maximum Panel
AD1	12"W x 12"H	60"W x 72"H
AD2	12"W x 14 ⁵ / ₈ "H	60"W x 72"H

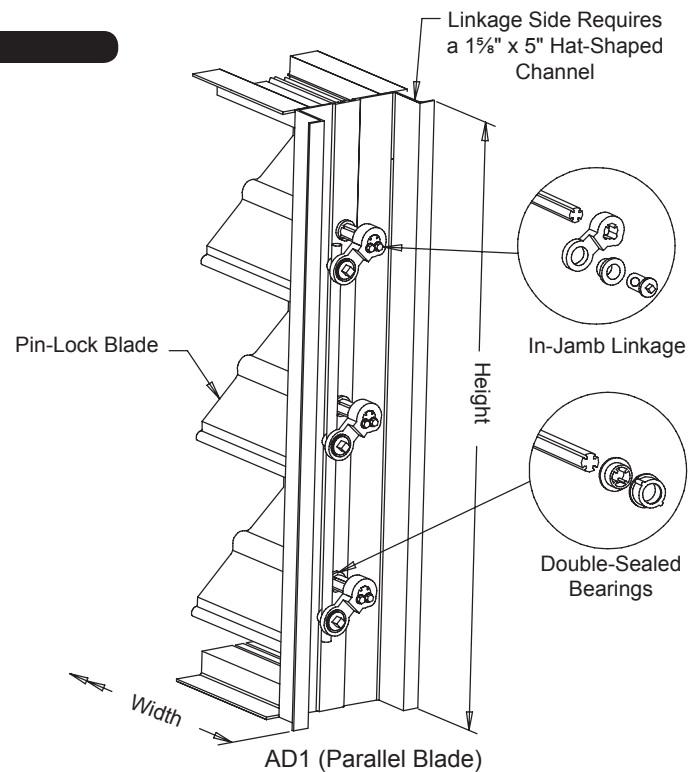
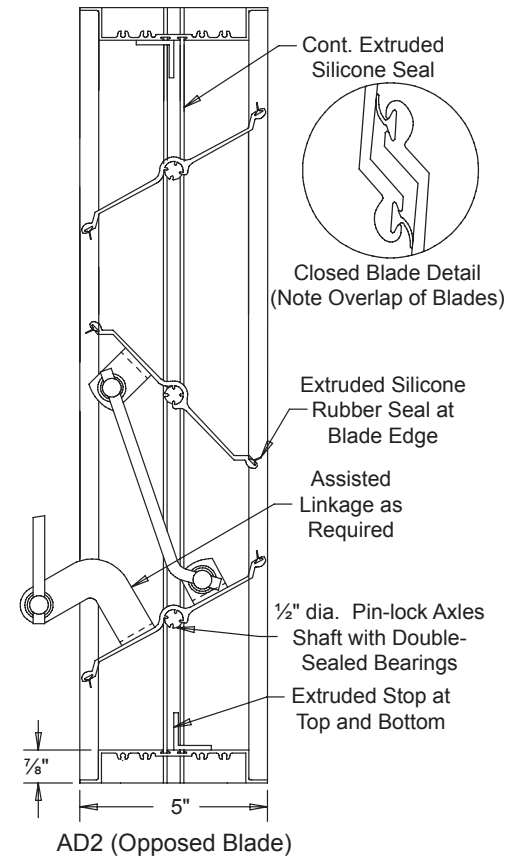
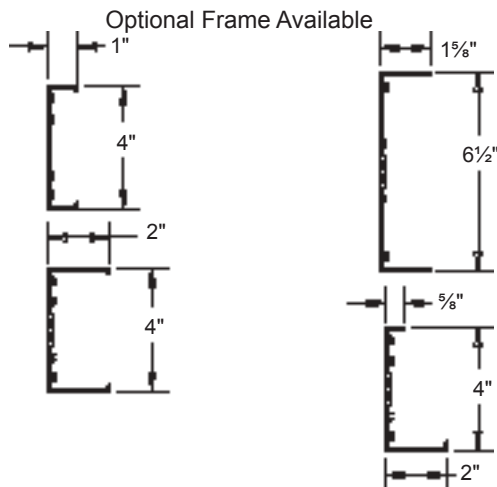

Louvers & Dampers
A Mccook Company

SD-AD1-2-09.08

P.O. Box 606 • Florence, KY 41042 • Phone (859) 647-2299 • Fax (859) 647-7810

August 2009

Performance Data:

Pressure Drop Ratings are based on AMCA Standard 500 using test set-up Fig. 5.3 for damper installed with duct upstream and downstream. Static pressures are corrected to .075 lb./cu.ft. air density.

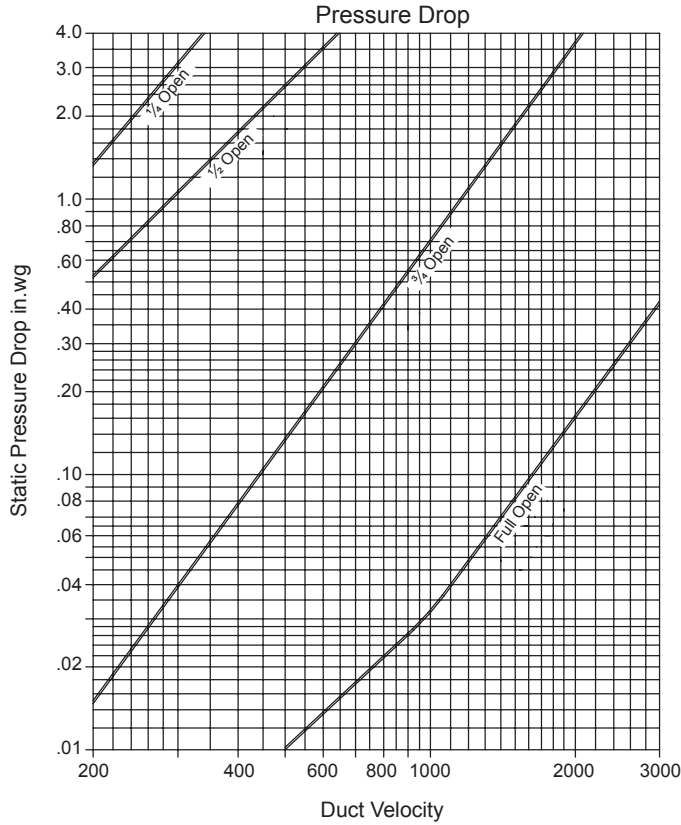

Air leakage ratings are based on AMCA Standard 500 using test set-up 5.4 the test results indicate exceptional low leakage. Damper leakage performance meets specifications requiring less than 1/2% of 1% for damper range of sizes.

Maximum Damper Width	Maximum System Static Pressure	Maximum System Velocity	Air Leakage
48"	2 in.wg	2000 fpm	7.5 cfm/sq.ft
36"	2.5 in.wg	2500 fpm	10.5 cfm/sq.ft
24"	2.5 in.wg	2500 fpm	10.5 cfm/sq.ft
12"	4.0 in.wg	3000 fpm	13.2 cfm/sq.ft