

# Aluminum Damper

**T28B/T29B**

5" Deep • Airfoil Blade • Thermal Break Aluminum Damper

**STANDARD CONSTRUCTION**

- FRAME:** 5" x .081" thick nominal 6063-T6/T52 extruded aluminum, hat shaped
- BLADES:** 6" x .080" thick nominal; 6063-T6/T52 extruded aluminum, airfoil profile injected with a two part polyurethane (cfc) free foam, and debridged for thermal isolation
- AXLES:** 1/2" dia. extruded aluminum, pin-lock design, interlocking into blade section
- BEARINGS:** Double-sealed with celcon inner bearing riding inside a polycarbonate outer bearing positively locked into frame, designed so that there shall be no metal-metal or metal-to-bearing riding surfaces
- LINKAGE:** Concealed in jamb of heavy aluminum; Crank arm permanently locked to blade axle by two stainless steel fasteners; The crank arm contains a 1/2" dia. metal pivot riding in a celcon bearing; A 1/4-20 set screw with locking patch ties the 5/16" dia. aluminum linkage rod; the linkage of each damper is individually adjusted
- SEALS:** Extreme low temperature seal system, extruded silicone rubber blade edge seal that fits into a ribbed groove insert in blades with an extruded polycarbonate seal at jamba
- FINISH:** Mill
- TEMP. LIMITS:** -40° to 200°

**OPTIONS**

- Hand Quadrants
- 120V, 24V, or Pneumatic Actuators
- Jackshaftering
- Auxillary Switch
- Explosion Proof Housing

**NOTES**

1. "A" width and "B" height are opening dimensions. Dampers are provided approximately 1/4" undersize.
2. Dampers with multiple panels in both width and height may require structural support. It is recommended that large openings be designed with structural members so that dampers will span either width or height with a single panel. ABI does not supply structural support with standard dampers.
3. Dampers more than one panel wide or high and operated with one actuator must be jackshafted. Factory supplied actuators are shipped loose to be mounted external as standard.
4. Not recommended for blades installed vertically.
5. Approximate damper weight is 6.5 lbs./sq.ft.

**DAMPER SIZE**

Panels	Minimum Panel	Maximum Panel
T88B	12"W x 8 7/8"H	60"W x 72"H
T29B	12"W x 12"H	60"W x 72"H

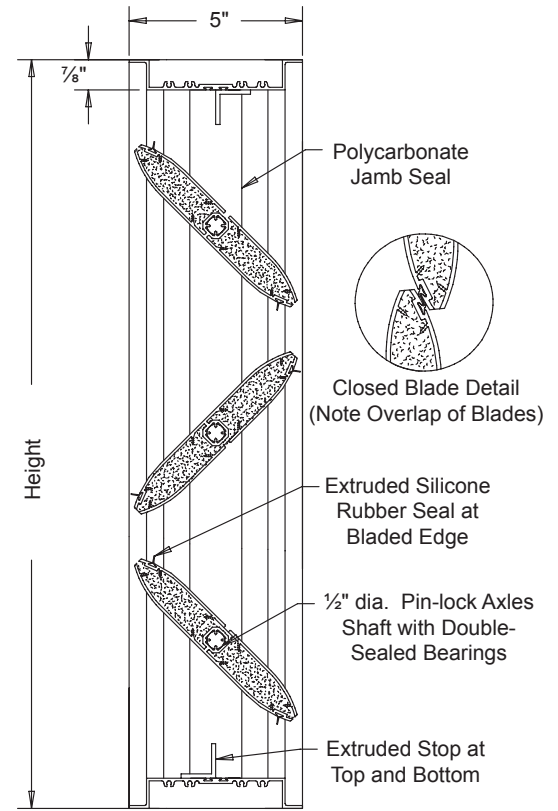

T29B

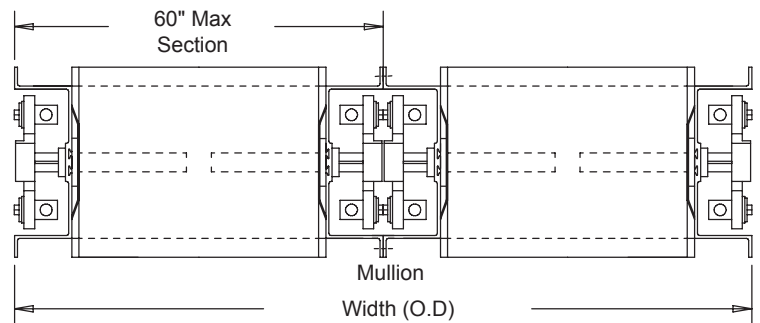

SD-T28-29B-09.08

P.O. Box 606 • Florence, KY 41042 • Phone (859) 647-2299 • Fax (859) 647-7810

August 2009

**Pressure Drop:**

Pressure Drop Ratings are based on AMCA Standard 500 using test set-up Fig. 5.3 for damper installed with duct upstream and downstream. Static pressures are corrected to .075 lb./cu.ft. air density.

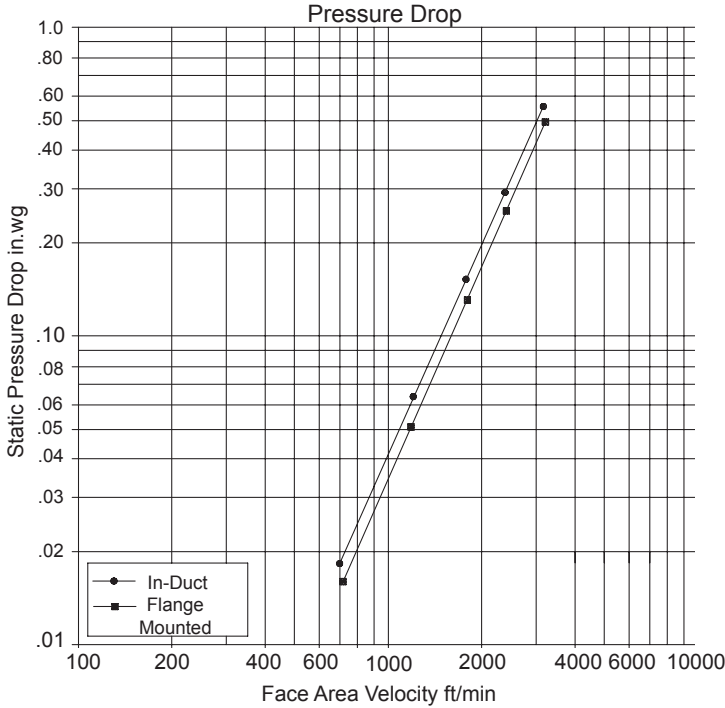

**Leakage**  
Total cfm Leakage at 1 in. wg Static Pressure Differential

		Width				
		12"	24"	36"	48"	60"
Height	12"	2	4	6	8	10
	18"	3	6	9	12	15
	24"	4	8	12	16	20
	30"	5	10	15	20	25
	36"	6	12	18	24	30
	42"	7	14	21	28	35
	48"	8	16	24	32	40
	54"	9	18	27	36	45
	60"	10	20	30	40	50
	66"	11	22	33	44	55
72"	12	24	36	48	60	

Leakage Ratings are based on AMCA Standard 500-D-97 using test set-up Fig. 5.4. Data is based on a closing torque of 5 in. lb./sq. ft. for dampers less than 5 sq. ft. having a closing torque of 40 in. lb. damper closing torque is applied to damper operating shaft.

**Leakage Correction Factor**

Damper Width 12" - 60"	Static Pressure in. wg						
	2"	3"	4"	5"	6"	7"	8"
	1.44	1.64	2.00	2.22	2.44	2.64	2.82

Use of correction factors will give leakage values at greater than 1" pressures.

**Damper Limitations**

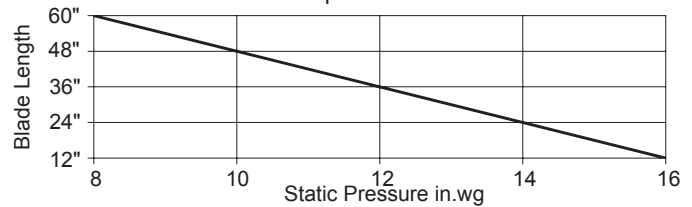

Model T28B/T29B damper design at reduced lengths can withstand higher static pressure limits without sacrificing damper operation and performance. Static pressures above 8 in. wg will affect operation torque value.

**Thermal Performance**

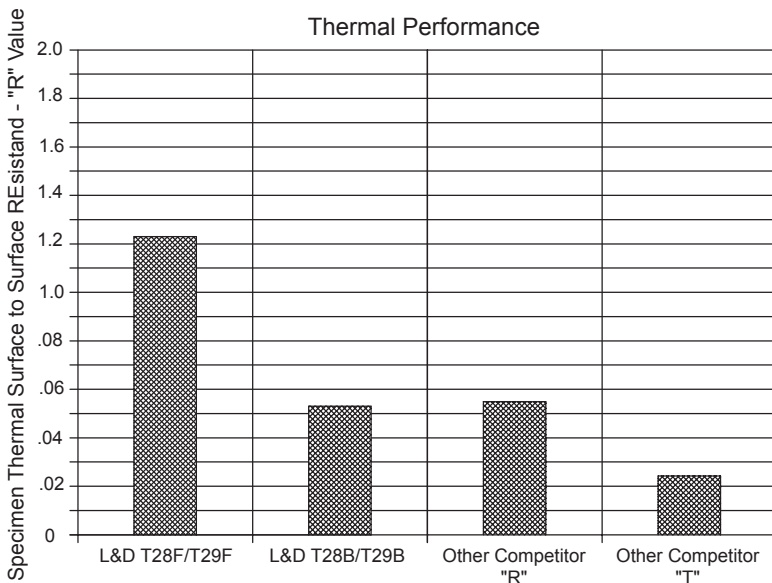

**Damper Limitations**

Damper Assembly Thermal Performance Rating Tested to ASTM C-1363-97, Standard Test Method for Thermal Performance of Building Assemblies by Means of a Hot Box Apparatus and Replaces C236 and C-975 Test Methods.