

# Multi-Blade Fire Damper

**17MD**

5½" Deep • 1½ Hour • Vertical or Horizontal Mount • Dynamically Rated Fire Damper

## STANDARD CONSTRUCTION

- FRAME:** 5½" x 7⁄8" x 16-GA galvanized steel hat channel
- BLADES:** 16-GA galvanized steel, 6" nominal width, parallel action
- AXLES:** Square, plated solid steel stub
- BEARINGS:** Oil impregnated bronze
- LINKAGE:** Plated steel angle and crank plates with stainless steel pivots in-jamb type
- STOPS:** 18-GA galvanized steel at head and sill
- JAMB SEALS:** Stainless Steel
- FINISH:** Mill
- ACTUATOR:** Non-motorized spring closure mechanism with 165°F fusible link

**UNDERWRITERS LABORATORIES INC.®**  
CLASSIFIED DYNAMIC FIRE DAMPER

FIRE RESISTANCE RATING 1½ HR  
IN ACCORDANCE WITH UL-555  
SEE U.L. FIRE RESISTANCE DIRECTORY



FILE #R16591



This fire damper meets the construction and performance requirements of

- Underwriters Laboratories Inc. Standards 555
- National Fire Protection Association Standards 80 and 90A
- ICC's International Building Code
- Underwriters Laboratories Inc. Approved for dual direction airflow and dynamic conditions.
- Underwriters Laboratories Inc. Classified for use in fire resistive ratings of less than 3 hours.

## OPTIONS

- Type 304 Stainless Steel Construction (Sleeve and in-airstream parts only)
- Sleeve of various depths and gauges
- Round or oval transitions
- 212°F fusible link
- Dual Position Indication Package (see Notes)

## NOTES

1. "A" width and "B" height are opening dimensions. Dampers are provided ¼" undercut.
2. Optional auxiliary blade position indication switches are rated at 11A, 1/3HP, 125VAC. These snap action switches are intended to make or break a circuit and will not provide variable or proportional resistance.
3. See SI-SSFD for information regarding Stainless Steel Fire Dampers.

## DAMPER SIZE

Orientation	Hor & Vert	2000 fpm, 4 in.wg				4000 fpm, 4 in.wg
		Horizontal (floor)		Vertical (wall)		Hor & Vert
Panels	Min Panel	Max Single Panel	Max Assy Panel	Max Single Panel	Max Assy Panel	Max Single Panel
Rectangular	4"W x 4"H (8"W x 8"H frame)	36"W x 48"H	72"W x 48"H	36"W x 48"H	72"W x 60"H 126"W x 48"H	36"W x 48"H
Round	6" dia. (8"W x 8"H frame)	34" dia.	46" dia.	34" dia.	58" dia.	34" dia.
Oval	6"W x 6"H (8"W x 8"H frame)	34"W x 46"H	70"W x 46"H	34"W x 46"H	70"W x 58"H 124"W x 46"H	34"W x 46"H

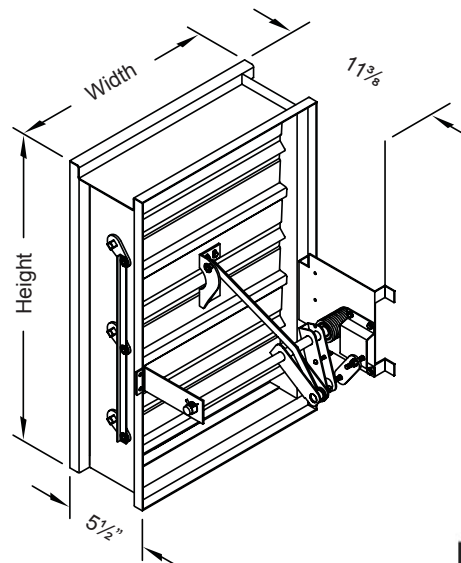

**Louvers & Dampers**  
A Metrotek Company

SD-17MD-11.02

P.O. Box 606 • Florence, KY 41042 • Phone (859) 647-2299 • Fax (859) 647-7810

February 2011

5½" Deep • 1½ Hour • Vertical or Horizontal Mount • Dynamically Rated Fire Damper

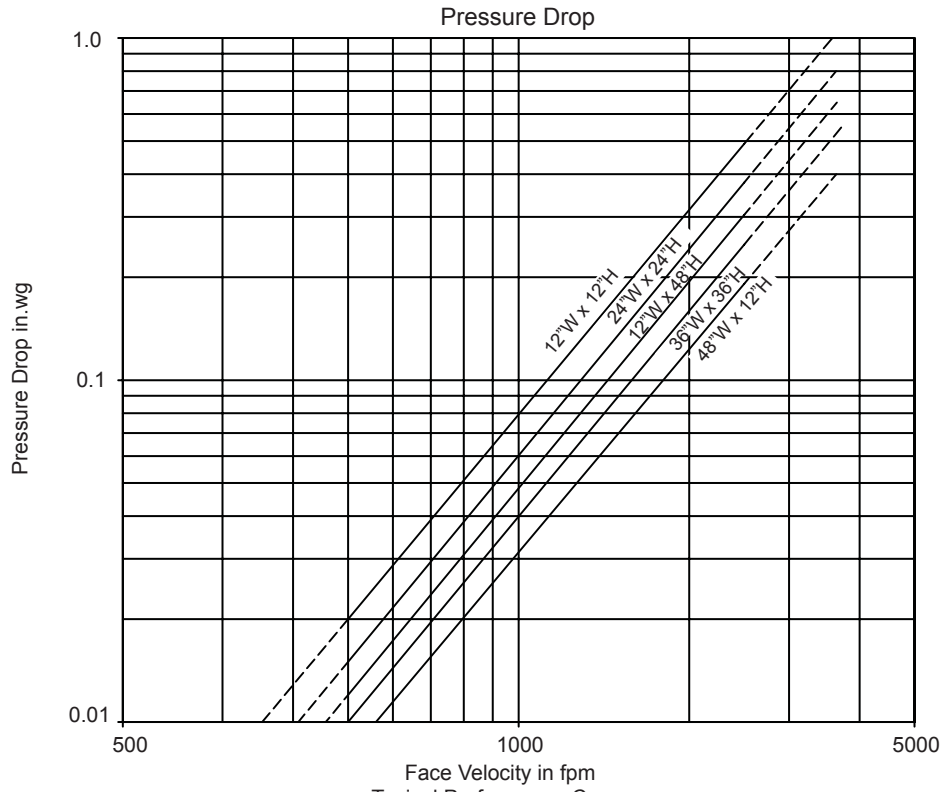

Typical Performance Curve  
 Tested per AMCA Standard 500-D; Figure 5.3 (In-Duct Mount)  
 (Smaller sizes will have higher pressure drops.)