

Grille Transfer for Curtain Fire Damper

Fire Damper • Models: 17SF, 17SA, 17DA

APPLICATION

This fire damper is intended to restrict the passage of flame. The standard installation requires that the damper is positioned so that the closed plane of the blades is within the fire rated masonry/concrete or metal or wood framed gypsum wallboard barrier.

This damper must be mounted in the vertical position with the damper blades running horizontally. Airflow can be from either direction. The damper can be mounted in a fire barrier constructed of masonry/concrete or metal or wood framed gypsum wallboard materials.

SIZE LIMITATIONS

		Orientation	Vertical
		Assembly	Maximum Panel
Model	17SF		40"W x 20"H
	17SA		40"W x 20"H
	17DA		36"W x 20"H

INSTALLATION

- Less than 3-Hour rated wood or metal framed or masonry vertical wall, barrier or partition constructed per UL's Fire Resistance Directory or other construction as approved by the AHJ. Fire resistant filler material lining the depth of the opening required when wood framing is used.
- 20-GA (minimum) steel sleeve with $1\frac{3}{16}$ " (minimum) flange. Sleeve depth to be flush or to extend beyond the non-flanged face of the barrier. Sleeve flange corners can be open only if a 26-GA (minimum) steel grille flange completely covers the damper sleeve flange. When metal framing, sleeve flange can be on top of or under the gypsum wallboard. When wood framing, sleeve flange must be on top of the gypsum wallboard.
- Attach the damper to the sleeve -
 17SF - The thinline fire damper is to be mounted within the plane of the fire barrier. The damper stitch is welded to the sleeve on both faces by $\frac{1}{2}$ " minimum long welds on 6" maximum centers. The first and last welds are not to exceed 3" from each corner.

 17SA/17DA - The standard frame fire damper is to be mounted within the plane of the fire barrier. The damper is attached to the sleeve using the same double row of fasteners used to mount the assembly to the opening. (See note #5 for details on fasteners.)

 17SA/17DA Alternate - The damper can be fastened to the sleeve on both faces of the damper using $\frac{1}{2}$ " long stitch welds or Tog-L-Loc type fasteners. Fasteners must be on 6" maximum centers with the first and last fasteners within 3" of each corner with a minimum of two fasteners per side of each face. Damper assembly attached to the opening using a double row of fasteners. (See note #5 for details on fasteners.)
- Attach grille to either the sleeve flange, the depth of the sleeve, or directly into the wall framing. Grille and its fasteners not provided by L&D.
- The fastener spacing to attach the damper assembly to the opening should not exceed 6". The first and last fasteners are not to exceed 3" from each corner, with a minimum of two fasteners per side. Fasteners must penetrate the wood or metal framing and not be embedded solely into the gypsum wallboard, Fasteners to be on both the flanged side of the damper and on the non-flanged side of the damper. Fasteners not provided by L&D.

The fasteners for masonry/concrete construction should be $\frac{3}{16}$ " diameter "Tapcon" or equal with a minimum of $1\frac{1}{2}$ " penetration.
 The fasteners for metal construction are fine thread, minimum #10, drywall screws with a minimum of 1" penetration into the framing.
 The fasteners for wood construction are coarse thread, minimum #10, drywall screw with a minimum of 1" penetration into the framing.

To insure a proper installation; remove the fuse link to cycle the damper, reopen the damper, re-install the fuse link identical to how the factory installed the fuse link.

- Minimum $\frac{1}{8}$ " expansion clearance is required in both width and height between the damper assembly and the opening.

Louvers  Dampers
A McCook Company

P.O. Box 606 • 7435 Industrial Rd • Florence, KY 41042 • Phone (859) 647-2299 • Fax (859) 647-7810

Grille Transfer for Curtain Fire Damper

Fire Damper • Models: 17SF, 17SA, 17DA

Thinline Curtain Fire Damper in Grille Transfer Opening
(Shown in Wood-Framed Opening)

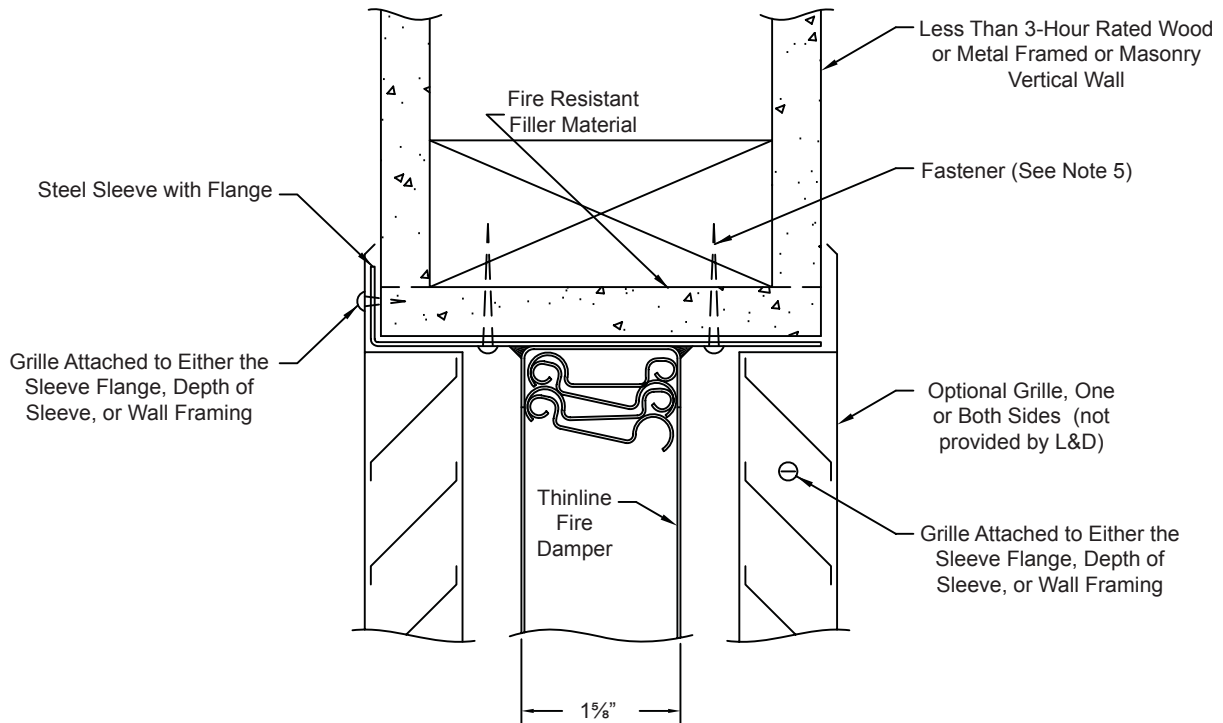

Standard Curtain Fire Damper in Grille Transfer Opening
(Shown in Wood-Framed Opening)

