

# Duct Access Door



1" Deep • Cammed or Hinged Door

## STANDARD CONSTRUCTION

- FRAME:** 22-GA galvanized steel
- DOOR PANEL:** 24-GA galvanized steel
- INSULATION:** 1" fiberglass
- PRE-FORMED TABS:** 22-GA galvanized steel
- FINISH:** Mill

## OPTIONS

- .032" Aluminum with Plated Steel Cams and Strikers
- 24-GA Stainless Steel with Stainless Steel Cams and Strikers

## NOTES

1. "A" width and "B" height are opening dimensions.
2. Standard construction to 4.5" Static Pressure.
3. On non standard doors, the height is always the larger dimension.

## DOOR SIZE

Panels	Standard Sizes	HDD100 Cams	HDD101 Cams
HDD	6"W x 6"H	1	2
	8"W x 8"H	1	2
	10"W x 10"H	1	2
	12"W x 12"H	1	2
	14"W x 14"H	1	2
	16"W x 16"H	2	4
	18"W x 18"H	2	4
	20"W x 20"H	2	4
	24"W x 24"H	2	4
	24"W x 36"H	3	6

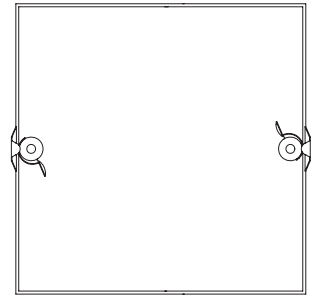

HDD101

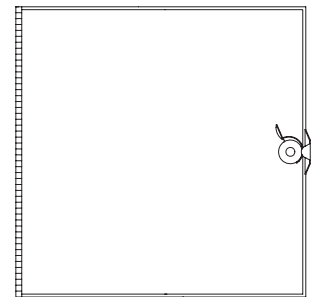

HDD100

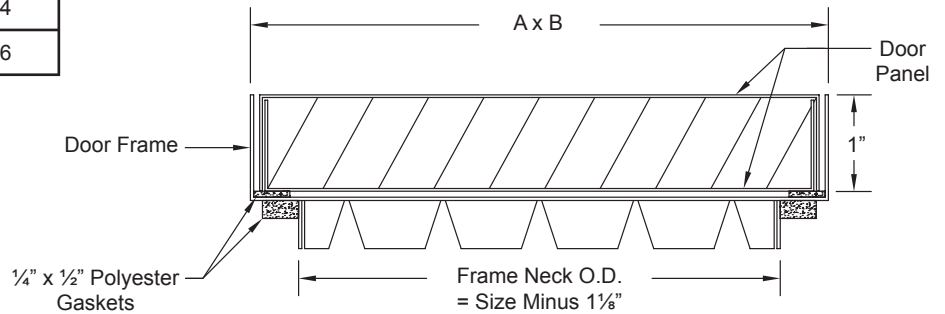

This page intentionally left blank.