

Duct Access Door

HDDH

1" Deep • High Pressure

STANDARD CONSTRUCTION

- FRAME:** 22-GA galvanized steel
- DOOR PANEL:** 24-GA galvanized steel
- INSULATION:** 1" fiberglass
- PRE-FORMED TABS:** 22-GA galvanized steel
- FINISH:** Mill

OPTIONS

- .032" Aluminum with Plated Steel Cams and Strikers
- 24-GA Stainless Steel with Stainless Steel Cams and Strikers

NOTES

1. "A" width and "B" height are opening dimensions.
2. Standard construction to 10" Static Pressure.

LOUVER SIZE

Panels	Standard Sizes	HDD100H Cams	HDD101H Cams
HDD	6"W x 6"H	3	4
	8"W x 8"H	3	4
	10"W x 10"H	3	4
	12"W x 12"H	3	4
	14"W x 14"H	3	4
	16"W x 16"H	6	8
	18"W x 18"H	6	8
	20"W x 20"H	6	8
	24"W x 24"H	6	8

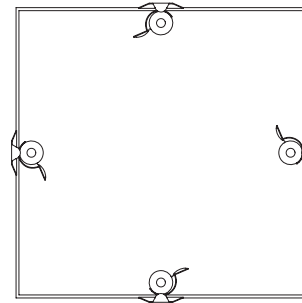

HDD101H

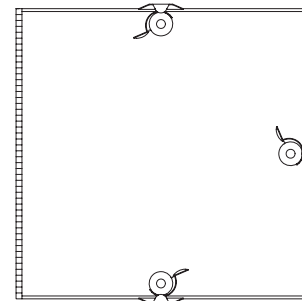

HDD100H

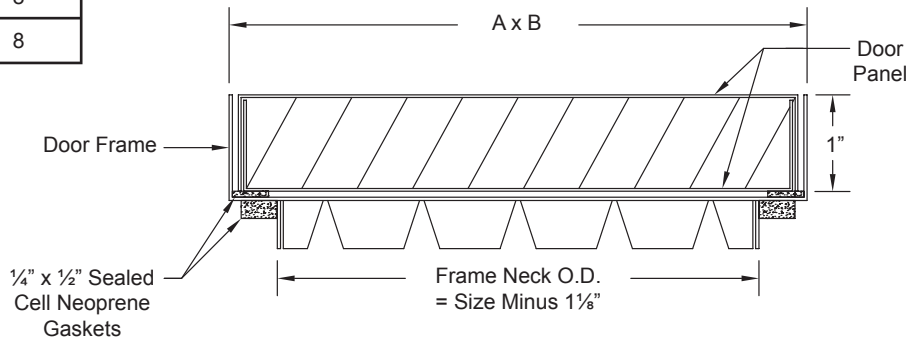

This page intentionally left blank.