

Fire/Smoke Damper

MA2G/F

Class I • 1½ Hour • 250°F or 350°F • Airfoil Blade • Front Access • UL Classified Damper

STANDARD CONSTRUCTION

- FRAME:** 5½" x 7⁄8" x 16-GA galvanized steel hat channel
- BLADES:** 20-GA double-skinned, equal to 14-GA; Parallel action
- AXLES:** Square, plated solid steel stub
- BEARINGS:** Oil impregnated bronze
- LINKAGE:** Plated steel angle and crank plates with stainless steel pivots; In-jamb type
- STOPS:** 20-GA galvanized steel at head and sill
- BLADE SEALS:** Silicone
- JAMB SEALS:** Stainless steel
- SLEEVE:** 20-GA galvanized steel by 15" long (1½" grille clearance) or 17" long (3½" grill clearance) with 1³⁄₁₆" front flange
- CAULKING:** Hardcast Irongrip 601 or UL-listed equivalent
- FINISH:** Mill on galvanized steel
- ACTUATOR:** Electric with heat response device (EHRD) or pneumatic with heat response device (PHRD); Factory-installed for Power-Open/Spring-Close (fail close) operation; Internally mounted and accessible from grille side

OPTIONS

- Integral Dual Position Indication (IDPI) Switches
- Sensotherm Re-Openable Heat Response Device (ESOT) for Electric Actuator
- Sensotherm Re-Openable Heat Response Device (ESOP) for Pneumatic Actuator
- Model SM-501 Flow-Rated Smoke Detector (10" Minimum Damper Height) Shipped Loose
- Model 2151 No-Flow Smoke Detector (14" Minimum Damper Height)
- Tab-Lock Retaining Angles
- Stainless Steel Bearings
- Copper Tubing (for Pneumatic Actuators)
- Sleeves of Various Gauge Thicknesses
- Round or Oval Transitions
- Short-Width (<10") and/or Short-Height (<10") Transitions

NOTES



1. Damper frames are provided approximately ¼" undersized. The addition of a sleeve and insulation will increase the size of the assembly. See II-FAGM for sizing openings.
2. Damper with smoke detector must have a minimum sleeve of 16" (1½" setback) or 18" (3" setback).
3. Dampers for horizontal installation can only be mounted in a fire barrier constructed of masonry/concrete materials.

DAMPER SIZE

Orientation	2000 fpm, 4 in.wg		
	Hor & Vert	Horizontal	Vertical
Panel	Min Panel	Max Panel	Max Panel
Rectangular	10"W x 10"H (10"W x 10"H frame)	32"W x 42"H	32"W x 42"H
Round	8" dia. (10"W x 10"H frame)	30" dia.	30" dia.
Oval	8"W x 8"H (10"W x 10"H frame)	30"W x 40"H	30"W x 40"H

*Dampers smaller than minimum frame size require a transition.
Reference SD-TRFS.

UNDERWRITERS LABORATORIES INC.®
CLASSIFIED DYNAMIC FIRE AND SMOKE DAMPER
FIRE RESISTANCE RATING 1½ HR
LEAKAGE RESISTANCE CLASS II

FILE #R16591

This combination fire/smoke damper meets the construction and performance requirements of:

- Underwriters Laboratories Inc. Standards 555 and 555S
- National Fire Protection Association Standards 80 and 90A
- ICC's International Building Code
- New York City MEA Listing #111-99-M
- California State Fire Marshal Listing #3225-1328:118
- Underwriters Laboratories Inc. Approved for dual direction airflow and dynamic conditions.
- Underwriters Laboratories Inc. Classified for use in fire resistive ratings of less than 3 hours.
- Underwriters Laboratories Inc. Classified for use in smoke control systems for Leakage Class II and 250°F or 350°F.
- Actuators must be arranged to operate automatically, must fail closed upon loss of power, and must be controlled by a smoke detection system.

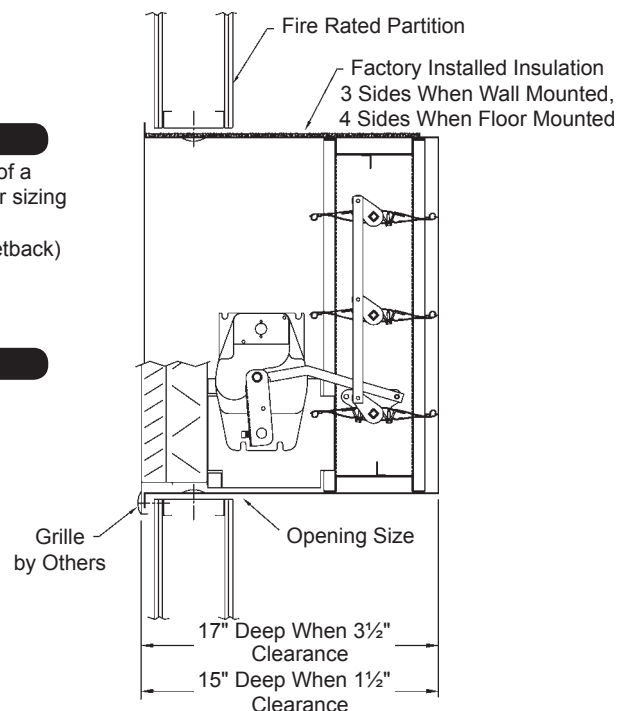

Operations Ratings:

Maximum Differential Pressure: 4 in. wg
 Maximum Velocity: 2000 fpm

Leakage Ratings:

UL Class II
 10 cfm per sq. ft. maximum @ 1 in. wg
 20 cfm per sq. ft. maximum @ 4 in. wg

Sound Ratings:

None Available

Pressure Drop Ratings:

The Pressure drop data shown below is based on laboratory conditions. The test setup does not take into account elbows or other duct fittings that are part of every actual duct system. The configuration of the actual duct system immediately upstream and downstream of the damper often contributes more pressure loss than the damper itself.

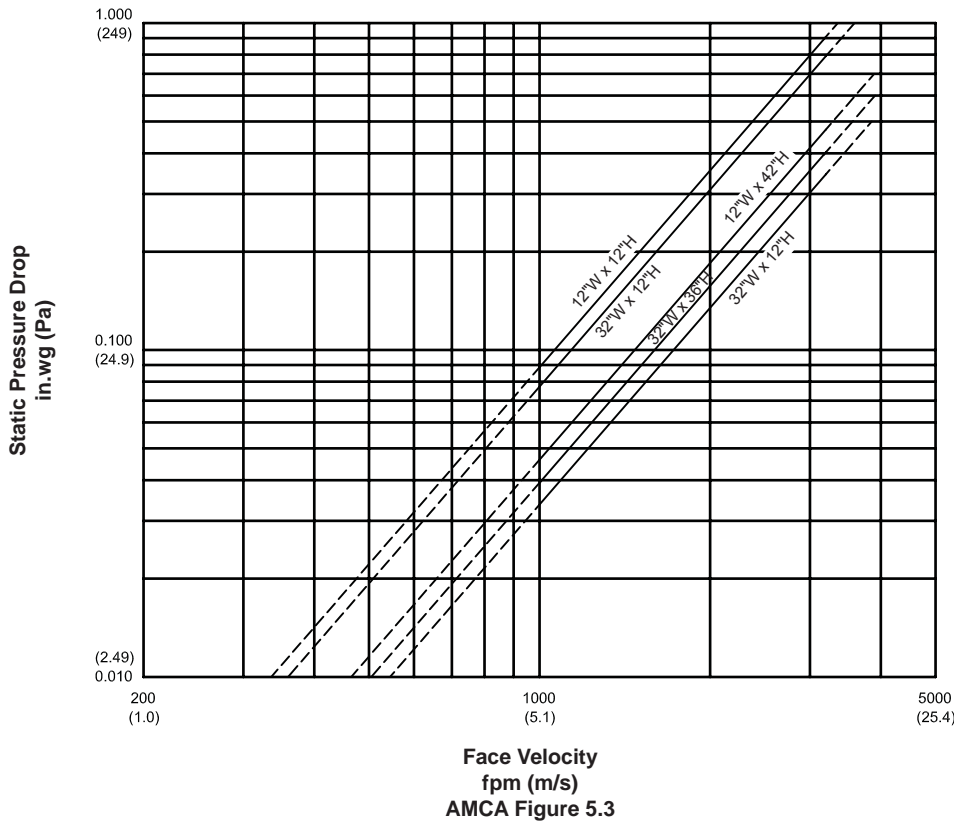

This product was tested in accordance with AMCA Standard 500D.