

Combination Fire/Smoke Damper

MS2(SS)

Class II • 250°F or 350°F • 1½ Hour • Stainless Steel • Single Thickness Blade

STANDARD CONSTRUCTION

- FRAME:** 5½" x 7⁄8" x 16-GA 304 stainless steel hat channel
- BLADES:** 16-GA 304 stainless steel single thickness; Parallel action
- AXLES:** 304 stainless steel stub
- BEARINGS:** Stainless steel
- LINKAGE:** 304 stainless steel angle and crank plates with stainless steel pivots; In-jamb type
- STOPS:** 18-GA 304 stainless steel at head and sill
- BLADE SEALS:** Silicone
- JAMB SEALS:** Stainless steel
- SLEEVE:** Minimum 20-GA 304 stainless steel by 18" long
- CAULKING:** Hardcast Irongrip 601 or UL-listed equivalent
- FINISH:** Mill on 304 stainless steel
- ACTUATOR:** Electric with heat response device (EHRD) or pneumatic with heat response device (PHRD); Factory-installed for Power-Open/Spring-Close (fail close) operation; External left hand mounted as viewed from jackshaft side of damper

UNDERWRITERS LABORATORIES INC.®
 CLASSIFIED DYNAMIC FIRE AND SMOKE DAMPER
 FIRE RESISTANCE RATING 1½ HR
 LEAKAGE RESISTANCE CLASS II

A Metstek Company

FILE #R16591



This combination fire/smoke damper meets the construction and performance requirements of:

- Underwriters Laboratories Inc. Standards 555 and 555S
- National Fire Protection Association Standards 80 and 90A
- ICC's International Building Code
- New York City MEA Listing #111-99-M
- California State Fire Marshal Listing #3225-1328:119
- Underwriters Laboratories Inc. Approved for dual direction airflow and dynamic conditions.
- Underwriters Laboratories Inc. Classified for use in fire resistive ratings of less than 3 hours.
- Underwriters Laboratories Inc. Classified for use in smoke control systems for Leakage Class II and 250°F or 350°F.
- Actuators must be arranged to operate automatically, must fail closed upon loss of power, and must be controlled by a smoke detection system.

OPTIONS

- Type 316 Stainless Steel (where available)
- External right hand actuator mounting location
- Integral Dual Position Indication (IDPI) switches
- Sensotherm re-openable heat response device (ESOT) for electric actuator
- Sensotherm re-openable heat response device (PSOT) for pneumatic actuator
- Model SM-501 Flow-rated smoke detector (10" minimum damper height)
- Tab-Lock retaining angles
- Copper tubing (for pneumatic actuators)
- Sleeves of various depths and gauge thicknesses
- Round or oval transitions
- Short-width (<8") and/or short-height (<8") transitions

NOTES

1. Damper frames are provided approximately ¼" undersized. The addition of a sleeve will increase the size of the assembly.
2. damper with smoke detector must have a minimum sleeve of 19" (10.5" on the actuator side and 3" on the non-actuator side).
3. Dampers for horizontal installation can only be mounted in a fire barrier constructed of masonry/concrete materials.

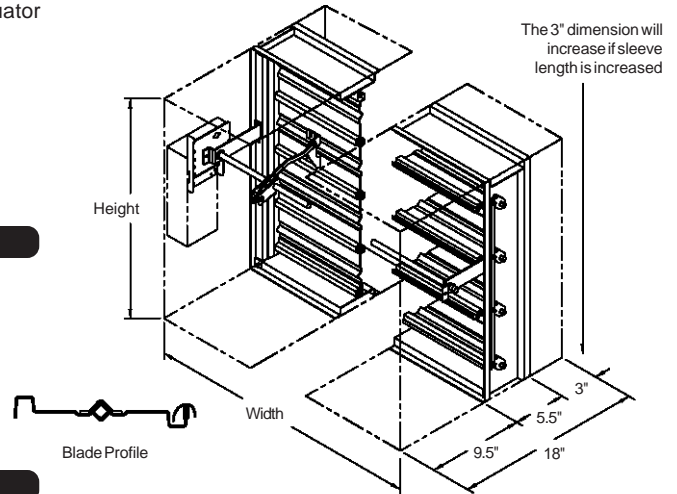

DAMPER SIZES

Orientation	Hor & Ver	2000 fpm 4 in.wg			3000 fpm 4 in.wg		
		Horizontal	Vertical		Horizontal	Vertical	
Panels	Min Panel	Max Panel	Max Panel	Max Assy	Max Panel	Max Panel	Max Assy
Rectangular	4"W 4"H (8"W x 8"H frame)	24"W x 24"H	36"W x 32"H	108"W x 32"H	24"W x 24"H	36"W x 32"H	108"W x 32"H
Round	4" dia. (8"W x 8"H frame)	22" dia.	30" dia.	not available	22" dia.	30" dia.	not available
Oval	4"W x 4"H (8"W x 8"H frame)	22"W x 22"H	34"W x 30"H	106"W x 30"H	22"W x 22"H	34"W x 30"H	106"W x 30"H

*Dampers smaller than minimum frame size require a transition. Reference SD-TRFS.



SD-MS2(SS)-08.04

P.O. Box 606 • 7435 Industrial Rd • Florence, KY 41042 • Phone (859) 647-2299 • Fax (859) 647-7810

April 2008

Operations Ratings:

Maximum Differential Pressure: 4 in. wg
 Maximum Velocity: 2000 fpm (3000 fpm for selected size/actuator combinations)

Leakage Ratings:

UL Class II
 10 cfm per sq. ft. maximum @ 1 in. wg
 20 cfm per sq. ft. maximum @ 4 in. wg

Sound Ratings:

The Noise Criterion data below was tested in accordance with ASTM E477.99 in the center octave band.

Noise Criterion (NC)				
Damper	Velocity (fpm)			
Size	1000	2000	3000	4000
12"W x 12"H (305mm x 305mm)	31	53	64	71
24"W x 24"H (610mm x 610mm)	33	54	65	not available

Pressure Drop Ratings:

The pressure drop data shown below is based on laboratory conditions. The test setup does not take into account elbows or other duct fittings that are part of every actual duct system. The configuration of the actual duct system immediately upstream and downstream of the damper often contributes more pressure loss than the damper itself.

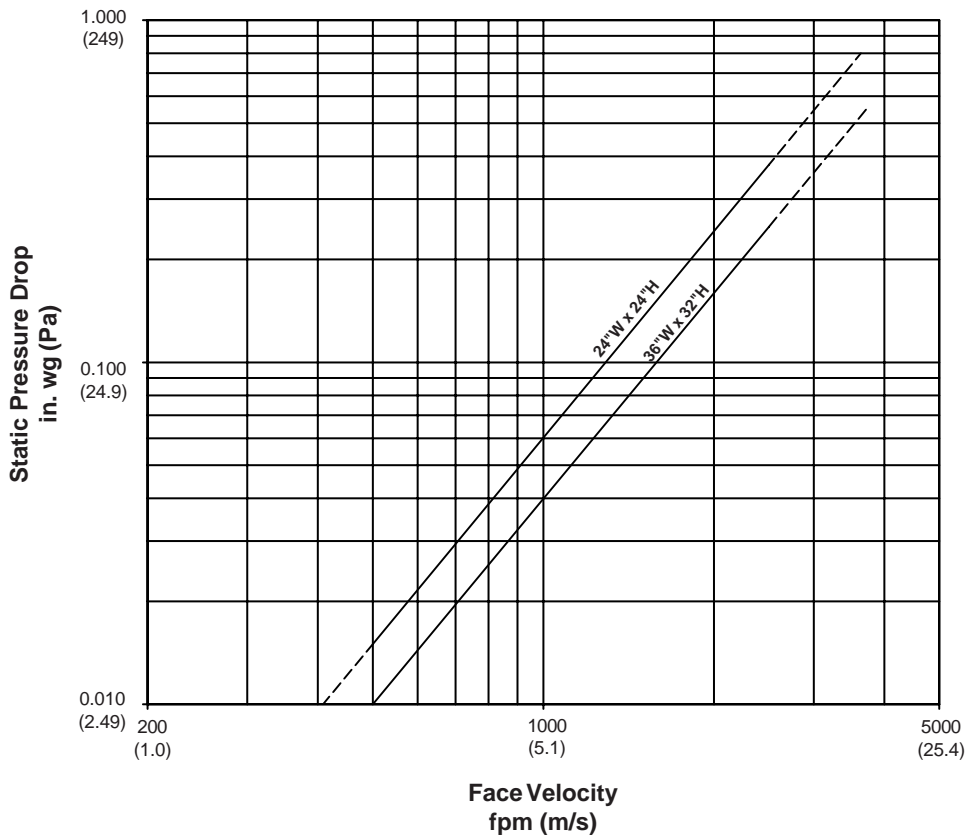

This product was tested in accordance with AMCA Standard 500D.

AMCA Figure 5.3