

Combination Fire/Smoke Damper

MT2

Class II • 250°F or 350°F • 3 Hour • Galvanized Steel • Single Thickness Blade

STANDARD CONSTRUCTION

- FRAME:** 5 1/2" x 7/8" x 16-GA galvanized steel hat channel; A flat head and sill are used for sizes thru 13" high
- BLADES:** 16-GA galvanized steel single thickness; Parallel action
- AXLES:** Plated solid steel stub
- BEARINGS:** Oil impregnated bronze
- LINKAGE:** Plated steel angle and crank plates with stainless steel pivots; In-jamb type or on-blade type
- STOPS:** 18-GA galvanized steel at head and sill
- BLADE SEALS:** Silicone
- JAMB SEALS:** Stainless steel
- SLEEVE:** Minimum 20-GA galvanized steel by 18" long (sizes greater than 84" wide or 84" high require minimum 18-GA)
- CAULKING:** Hardcast Irongrip 601 or UL-listed equivalent
- FINISH:** Mill on galvanized steel
- ACTUATOR:** Electric with heat response device (EHRD) or pneumatic with heat response device (PHRD); Factory-installed for Power-Open/Spring-Close (fail close) operation; External left hand mounted as viewed from jackshaft side of damper; Any additional actuators will be internally mounted

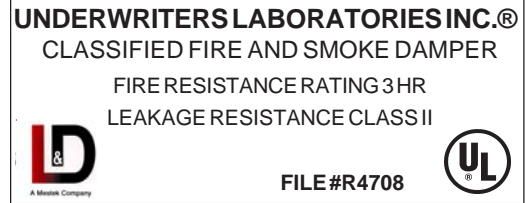

This combination fire/smoke damper meets the construction and performance requirements of:

- Underwriters Laboratories Inc. Standards 555 and 555S
- National Fire Protection Association Standards 90A, 92A, and 92B
- ICC's International Building Code
- ICBO's Uniform Building Code
- SBCCI's Standard Building Code
- BOCA's National Building Code
- New York City MEA Listing #111-99-M
- California State Fire Marshal Listing #3225-1328:115
- Underwriters Laboratories Inc. Approved for dual direction airflow and dynamic conditions.
- Underwriters Laboratories Inc. Classified for use in fire resistive ratings of 3 hours and longer.
- Underwriters Laboratories Inc. Classified for use in smoke control systems for Leakage Class II and 250°F or 350°F.
- Actuators must be arranged to operate automatically, must fail closed upon loss of power, and must be controlled by a smoke detection system.

OPTIONS

- Right hand and/or internal actuator mounting locations (restrictions apply)
- Integral Dual Position Indication switches (IDPI)
- Sensotherm re-openable heat response device (ESOT) for electric actuator
- Sensotherm re-openable heat response device (EPOT) for pneumatic actuator
- Model SM-501 Flow-rated smoke detector (10" minimum damper height)
- Model 2151 No-flow smoke detector (12" minimum damper height)
- Tab-Lock retaining angles
- Stainless steel bearings
- Copper tubing (for pneumatic actuators)
- Sleeves of various depths and gauge thicknesses
- No sleeve or sideplate only (restrictions apply)
- Round or oval transitions
- Short-width (<8") and/or short-height (<8") transitions

NOTES

1. Damper frames are provided approximately 1/4" undersized. The addition of a sleeve will increase the size of the assembly.
2. Damper with smoke detector must have a minimum sleeve of 19" (10.5" on the actuator side and 3" on the non-actuator side).
3. Dampers for horizontal installation can only be mounted in a fire barrier constructed on masonry/concrete material.

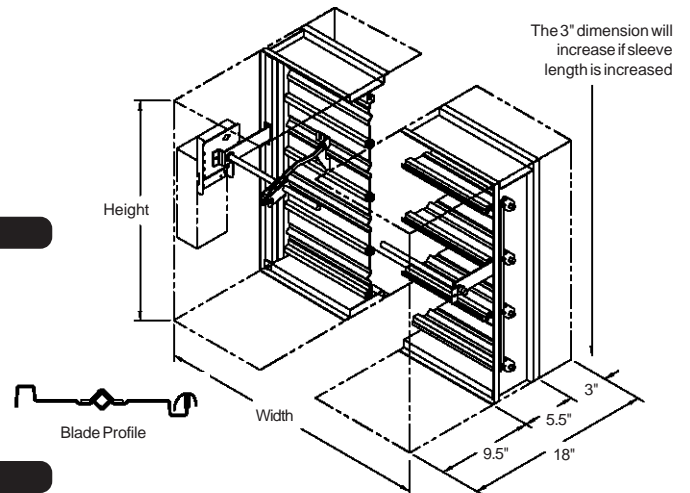

DAMPER SIZES

Orientation	Hor & Ver	Horizontal (floor)		Vertical (wall)			
		Max Panel	Max Assy	Max Panel 250°	Max Panel 350°	Max Assy 250°	Max Assy 350°
Rectangular	4"Wx4"H (16"Wx8"H frame)	30"Wx48"H or 36"Wx30"H	60"Wx48"H	36"Wx48"H or 42"Wx36"H	36"Wx48"H	108"Wx48"H	108"Wx48"H
Round	4" dia. (16"Wx8"H frame)	28" dia.	46" dia.	34" dia.	34" dia.	46" dia.	46" dia.
Oval	4"Wx4"H (16"Wx8"H frame)	28"Wx46"H or 34"Wx28"H	58"Wx46"H	34"Wx46"H or 40"Wx34"H	34"Wx46"H	106"Wx46"H	106"Wx46"H

*Dampers smaller than minimum frame size require a transition. Reference SD-TRFS.



SD-MT2-08.04

P.O. Box 606 • 7435 Industrial Rd • Florence, KY 41042 • Phone (859) 647-2299 • Fax (859) 647-7810

April 2008

Operations Ratings:

Maximum Differential Pressure: 4 in. wg
 Maximum Velocity: 2000 fpm (3000 fpm for selected size/actuator combinations)

Leakage Ratings:

UL Class II
 10 cfm per sq. ft. maximum @ 1 in. wg
 20 cfm per sq. ft. maximum @ 4 in. wg

Sound Ratings:

The Noise Criterion data below was tested in accordance with ASTM E477.99 in the center octave band.

Noise Criterion (NC)				
Damper Size	Velocity (fpm)			
	1000	2000	3000	4000
12" W x 12" H (305mm x 305mm)	31	53	64	71
24" W x 24" H (610mm x 610mm)	33	54	65	not available

Pressure Drop Ratings:

The pressure drop data shown below is based on laboratory conditions. The test setup does not take into account elbows or other duct fittings that are part of every actual duct system. The configuration of the actual duct system immediately upstream and downstream of the damper often contributes more pressure loss than the damper itself.

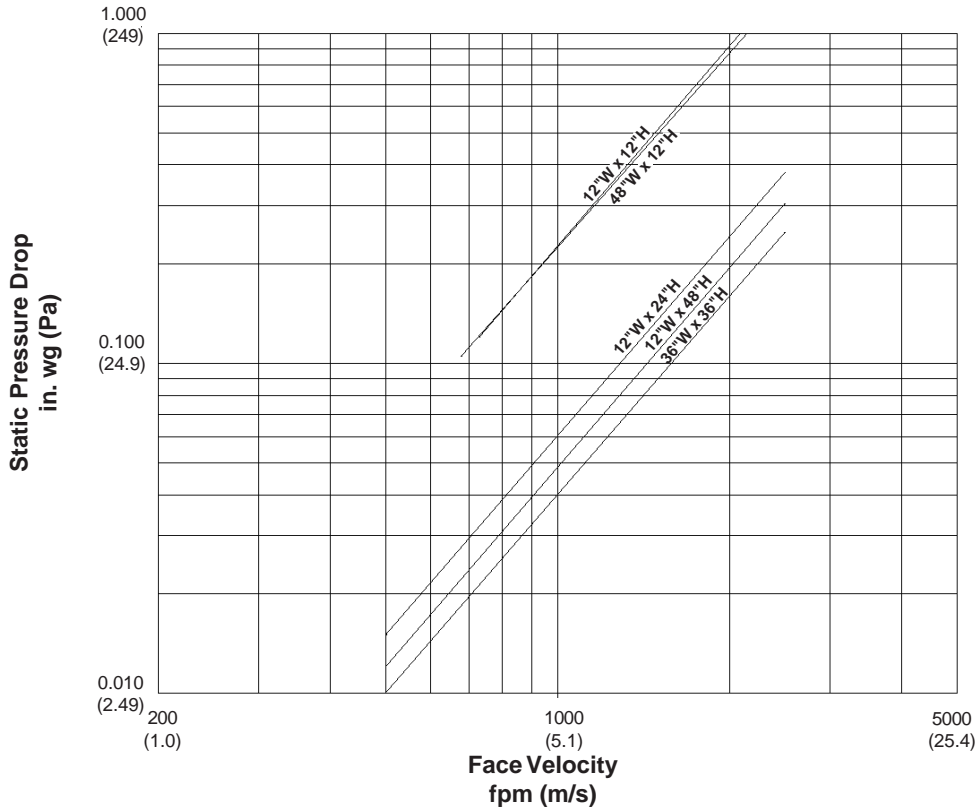

This product was tested in accordance with AMCA Standard 500D.

AMCA Figure 5.3