

Combination Fire/Smoke Damper

RM

Class I • 250°F or 350°F • Galvanized Steel • Single Thickness Blade • True Round F/S Damper

STANDARD CONSTRUCTION

- FRAME:** 20-GA galvanized rolled frame; 18" deep
- BLADES:** 20-GA double thickness galvanized steel (equal to 14-GA)
- AXLES:** ½" diameter galvanized or plated steel, full length
- BEARING:** Oil impregnated bronze sleeve
- STOPS:** Full open and full closed angle stops
- BLADE SEAL:** Silicone
- CAULKING:** UL approved
- FINISH:** Mill
- ACTUATOR:** Electric; Factory-installed for Power-Open/Spring-Close (fail close) operation; External left hand mounted as viewed from jackshaft side of damper

OPTIONS

- Right hand actuator mounting location
- Integral Dual position Indication (IDPI) switches
- Model SM-501 Flow-rated smoke detector; ship loose only
- Model 2151 No-flow smoke detector; ship loose only
- Rolled retaining angles
- Stainless steel bearings
- Copper tubing (for pneumatic actuators)
- Sleeves of various depths (consult factory)
- Retaining Plates
- Pneumatic Actuator



NOTES

1. Dampers are provided approximately ⅛" undersize.
2. Dampers available in 2" increments only.
3. Dampers ≥ 20" require factory installed rings in center of damper.

DAMPER SIZE

		2000 fpm, 4 in.wg		3000 fpm, 6 in.wg	
Orientation	Hor & Vert	Hor & Vert	Hor & Vert	Hor & Vert	Hor & Vert
Panels	Minimum Panel	Maximum Panel	Maximum Panel	Maximum Panel	Maximum Panel
RM	6" dia.	24" dia.	24" dia.	24" dia.	24" dia.

UNDERWRITERS LABORATORIES INC.®
 CLASSIFIED DYNAMIC FIRE AND SMOKE DAMPER
 FIRE RESISTANCE RATING 1½ HR
 LEAKAGE RESISTANCE CLASS I

FILE #R16591

This fire/smoke damper meets the construction and performance requirements of:

- Underwriters Laboratories Inc. Standard 555S and 555
- National Fire Protection Association Standards 80 and 90A
- ICC's International Building Code
- California State Fire Marshal Listing #3225-1328:123
- Underwriters Laboratories Inc. Approved for dual direction airflow and dynamic conditions.
- Underwriters Laboratories Inc. Classified for use in fire resistive ratings of less than 3 hours.
- Underwriters Laboratories Inc. Classified for use in smoke control systems for Leakage Class I and 250°F or 350°F.
- Actuators must be arranged to operate automatically, must fail closed upon loss of power, and must be controlled by a smoke detection system.

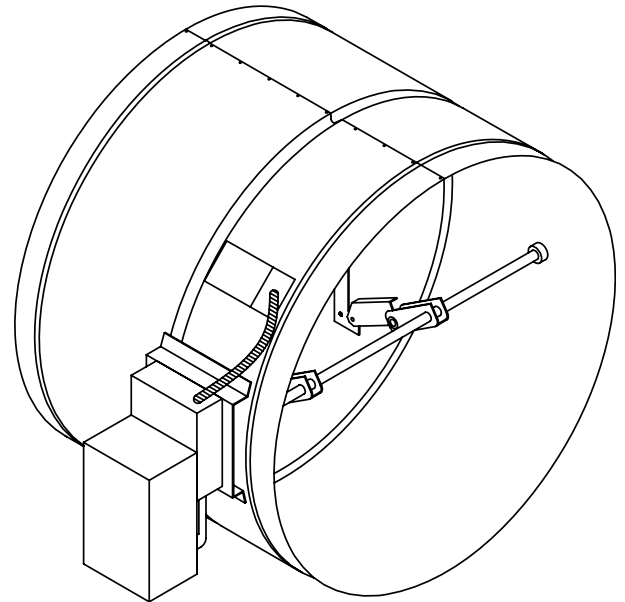

Operations Ratings:

Maximum Differential Pressure: 4 in.wg (6 in.wg depending on actuator selection)
 Maximum Velocity: 2000 fpm (3000 fpm depending on actuator selection)

Leakage Ratings:

UL Class I
 8 cfm per sq. ft. maximum @ 4 in.wg

Sound Ratings:

None Available

Pressure Drop Ratings:

The pressure drop data shown below is based on laboratory conditions. The test setup does not take into account elbows or other duct fittings that are part of every actual duct system. The configuration of the actual duct system immediately upstream and downstream of the damper often contributes more pressure loss than the damper itself.

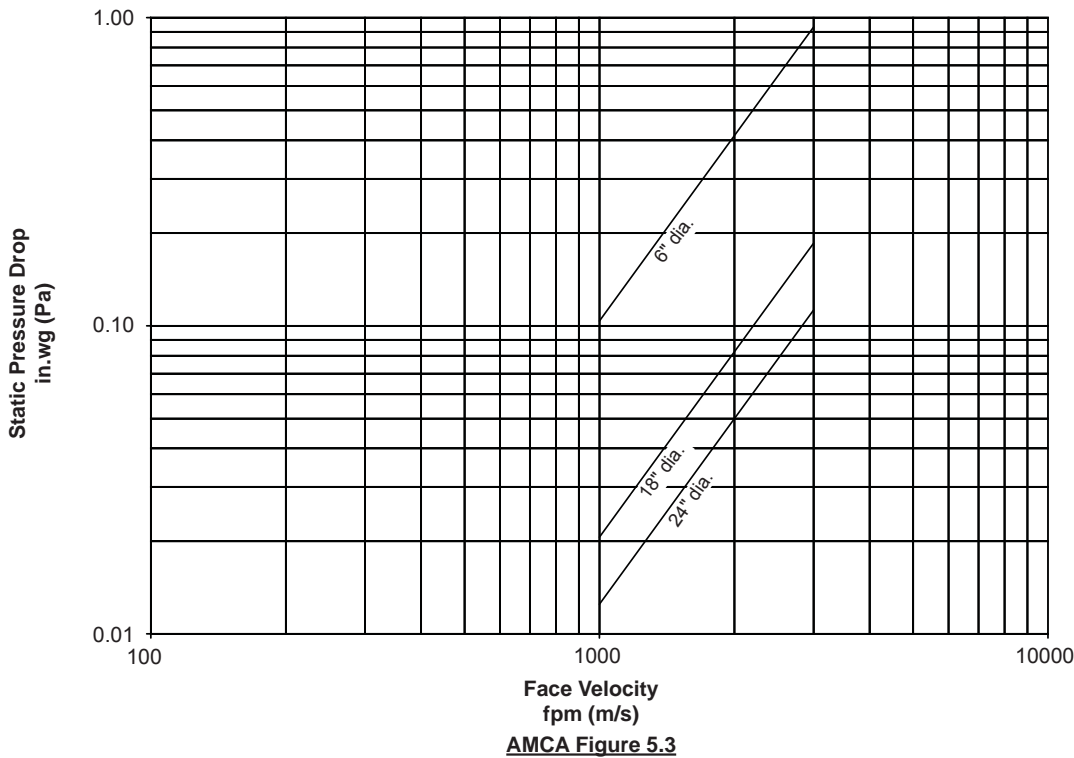

This product was tested in accordance with AMCA Standard 500D.