

GRAVITY VENTILATOR

AGV-P

STANDARD CONSTRUCTION

Low Profile
Formed Aluminum

MATERIAL

Hood is of .050" aluminum and throat and curb cap are of .080" thick extruded aluminum, alloy 6063-T5. Exterior corner bracing is 3/4" x 3/4" x 1/8" extruded aluminum angle 6063-T5 alloy. Internal support bracing is 1" x 2" x 1" extruded aluminum channel. Additional support bracing is added when either hood dimension exceeds 47". Hoods built in sections are of .063" aluminum and include adequate additional support bracing.

ASSEMBLY

All hoods are mechanically fastened to the throat. Bracing is solid welded through out. Curb cap joints are solid seal welded to prevent leakage.

SCREEN

1/2" bird screen mechanically fastened to underside of hood.

FINISH

Mill finish.

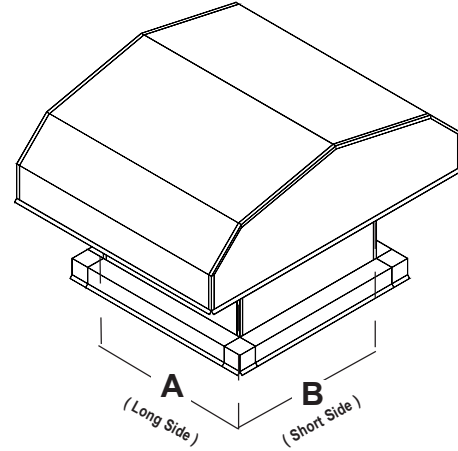

FREE AREA and MODELS

100% (1:1)
Exhaust

200% (2:1)
Intake

AGV-P1

AGV-P2

CHAMFERED ROOF ENDS
(on short (B) dimension)
Reduces Turbulence,
Decreases Pressure Drop and
Enhances Airflow

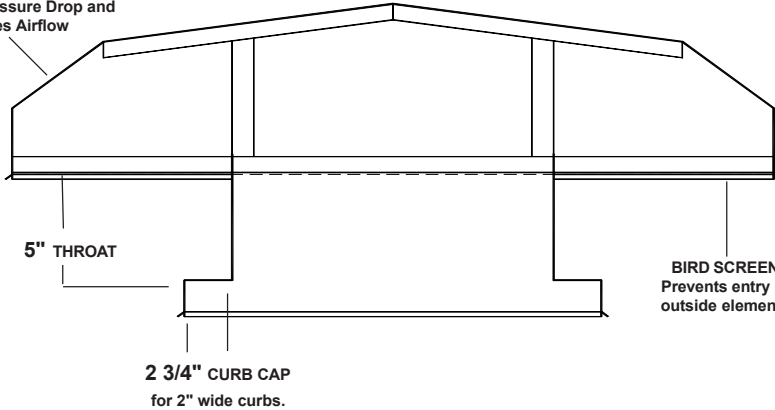

BIRD SCREEN
Prevents entry of
outside elements

Model	'A' (throat width)	'B' (throat width)	Qty	Options / Accessories / Variations

PROJECT _____ LOCATION _____
 ARCH/ENGR _____ CONTRACTOR _____
 REPRESENTATIVE _____ DATE _____

PC00051(1) - SEPT. 2001

GRAVITY VENTILATORS

ID Louvers & Dampers
A DIVISION OF MESTEK, INC.

P.O. Box 606 • 7435 Industrial Rd • Florence, KY 41042 • Phone (859) 647-2299 • Fax (859) 647-7810

AGV-P

HOOD DIMENSIONS

- Find dimensions A x B in selected Free Area sizing chart to determine overall hood height and width.
- Standard throat height is 5" (other heights are available). To determine overall ventilator height add 'C' dimension and throat height (5").
- Standard curb cap is 2 3/4" (other sizes are available).
- Sizes with dimensions in reverse will ship in multiple sections and require field assembly.

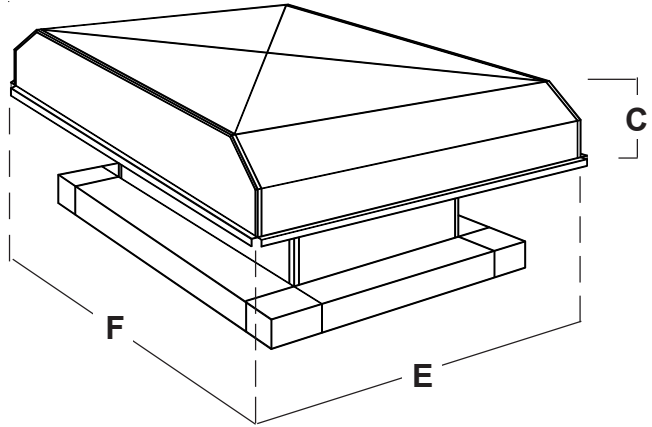

		A Dimension (LONG throat width) Square End													
		12"	14"	16"	18"	20"	24"	30"	36"	42"	48"	54"	60"	66"	72"
B Dimension (SHORT throat width) Chamfered End	12" C	6	6	6	7	7	7	7	7	8	8	8	9	9	9
	12" E	20	20	20	18	20	18	17	17	17	17	17	17	17	17
	12" F	20	23	27	28	32	37	44	53	61	70	79	87	96	105
	14" C		7	7	7	7	7	8	8	8	9	9	9	10	10
	14" E		23	22	22	21	21	21	21	21	21	21	21	21	21
	14" F		23	25	28	31	35	44	53	61	70	79	87	96	105
	16" C			7	8	8	8	8	8	9	9	9	10	10	10
	16" E			25	25	23	23	23	23	23	23	23	23	23	23
	16" F			25	28	29	35	44	53	61	70	79	87	96	105
	18" C				8	8	8	9	9	9	9	10	10	11	11
	18" E				26	26	26	26	26	26	26	26	26	26	26
	18" F				27	28	35	44	53	61	70	79	87	96	105
	20" C					9	9	9	9	10	10	11	11	11	12
	20" E					29	29	29	29	29	29	29	29	29	29
	20" F					29	35	44	53	61	70	79	87	96	105
	24" C						10	10	10	11	11	12	12	12	13
	24" E						35	35	35	35	35	35	35	35	35
	24" F						35	44	53	61	70	79	87	96	105
30" C							11	12	12	13	13	14	14	14	
30" E							44	44	44	44	44	44	44	44	
30" F							44	53	61	70	79	87	96	105	
36" C								13	14	14	15	15	16	16	
36" E								52	52	52	52	52	52	52	
36" F								53	61	70	79	87	96	105	
42" C									15	15	16	17	17	18	
42" E									58	58	58	58	58	58	
42" F									64	73	83	92	101	110	
48" C										17	17	18	19	20	
48" E										70	70	70	70	70	
48" F										70	79	87	96	105	
54" C											18	18	18	18	
54" E											78	78	78	78	
54" F											79	87	96	105	
60" C												20	20	20	
60" E												87	87	87	
60" F												87	96	105	
66" C													22	22	
66" E													93	93	
66" F													99	108	
72" C														24	
72" E														93	
72" F														118	

100% (1:1) Exhaust

NOTE: FRACTIONS ARE ROUNDED

		A Dimension (LONG throat width) Square End													
		12"	14"	16"	18"	20"	24"	30"	36"	42"	48"	54"	60"	66"	72"
B Dimension (SHORT throat width) Chamfered End	12" C	8	8	8	8	8	9	9	10	10	11	11	12	12	13
	12" E	23	23	23	23	23	23	23	23	23	23	23	23	23	23
	12" F	23	27	30	34	38	46	57	69	80	91	103	114	126	137
	14" C		8	8	8	8	8	9	9	10	10	11	11	12	13
	14" E		26	26	26	26	26	26	26	26	26	26	26	26	26
	14" F		26	30	34	38	45	57	68	79	90	102	113	124	136
	16" C			8	8	8	8	9	9	10	10	11	11	12	13
	16" E			30	30	30	30	30	30	30	30	30	30	30	30
	16" F			30	34	37	45	56	67	78	90	101	112	123	134
	18" C				8	8	8	9	9	10	10	11	11	12	13
	18" E				34	34	34	34	34	34	34	34	34	34	34
	18" F				33	37	44	56	67	78	89	100	111	122	133
	20" C					8	8	8	9	10	10	11	11	12	13
	20" E					36	36	36	36	36	36	36	36	36	36
	20" F					36	43	54	65	76	87	98	108	119	130
	24" C						11	11	12	12	13	14	14	15	16
	24" E						43	43	43	43	43	43	43	43	43
	24" F						44	54	65	76	87	98	109	120	131
30" C							14	14	15	16	17	17	18	19	
30" E							54	54	54	54	54	54	54	54	
30" F							54	65	76	87	98	108	119	130	
36" C								17	17	18	19	20	21	22	
36" E								60	60	60	60	60	60	60	
36" F								70	82	94	105	117	129	140	
42" C									19	20	21	22	23	24	
42" E									76	76	76	76	76	76	
42" F									75	86	97	108	119	129	
48" C										22	23	24	25	27	
48" E										87	87	87	87	87	
48" F										86	97	108	118	129	
54" C											27	27	27	27	
54" E											93	93	93	93	
54" F											102	113	125	136	
60" C												27	27	27	
60" E												93	93	93	
60" F												126	138	151	
66" C													27	23	
66" E													93	93	
66" F													152	159	
72" C														24	
72" E														117	
72" F														144	

200% (2:1) Intake

NOTE: DIMENSIONS ARE ROUNDED

STATIC PRESSURE LOSS (inches w.g.)

Throat Velocity	100%	200%	
	EXHAUST	INTAKE	EXHAUST
300 fpm	.012"	.018"	.008"
400 fpm	.021"	.031"	.013"
500 fpm	.033"	.049"	.021"
600 fpm	.048"	.071"	.030"
700 fpm	.065"	.096"	.041"
800 fpm	.085"	.126"	.053"
900 fpm	.108"	.159"	.068"
1000 fpm	.133"	.196"	.084"
1100 fpm	.161"	.237"	.101"
1200 fpm	.192"	.282"	.120"

FORMULAS

1) HOOD VELOCITY (fpm)

$$\text{Throat Velocity (FPM)} \div \begin{matrix} 1 & \text{(100\% Free Area)} \\ 2 & \text{(200\% Free Area)} \end{matrix}$$

2) THROAT VELOCITY (fpm)

$$\text{Hood Velocity (FPM)} \times \begin{matrix} 1 & \text{(100\% Free Area)} \\ 2 & \text{(200\% Free Area)} \end{matrix}$$

3) THROAT SIZE (square feet)

$$\text{Air Flow (CFM)} \div \text{Throat Velocity (FPM)}$$

4) THROAT PERIMETER (inches)

$$A + A + B + B$$

SIZING RECOMMENDATIONS

- 1) On *INTAKE* Gravity Ventilators, the *Hood Velocity should not exceed 600 fpm*.
- 2) To size a **2" Curb** using the standard gravity ventilator curb cap of 2 3/4", add **throat size + 4"** to allow for the curb cap distance from the throat with adequate installation allowance.

OPTIONS / ACCESSORIES

SCREENS

A wide variety of Bird or Insect screens are available in various gauges and mesh dimensions including a snow screen.

MATERIAL

Aluminum thickness in .063" or .081" on hood.

CURB CAP

Standard is 2 3/4" for 2" curbs, although by specifying, curb cap is available in any size.

THROAT OPTIONS

Standard exposed throat height of 5" can be extended to any selected height. Hoods (throat sizes up to 60" x 60") can be hinged to throat for swing open access from one side or split horizontally creating two sections for lift up access.

INSULATION/ANTI CONDENSATE

Mastic coating is available on the underside of the hood or insulation (1" or 2") can be installed in either the hood or the throat.

HEAVY CONSTRUCTION

For high wind area applications, our high wind loading option assures your gravity ventilator will remain intact under wind conditions up to 125 mile per hour.

DAMPER MOUNT

Dampers can be mounted horizontally in the throat or vertically around the inside perimeter of the hood.

FILTERS AND RACKS

1" or 2" filters and racks, available in Disposable or Washable (Note: disposable available on specific sizes only).

FINISHES

A wide selection of finishes including Baked Enamel, Epoxy and Prime Coat.