

Formed Steel Louver

SL67

6" Deep • 30° Non-Drainable Blade • Formed Steel Stationary Louver

STANDARD CONSTRUCTION

- FRAME:** 18-GA galvanized steel channel type
- BLADES:** 18-GA galvanized steel
- BLADE SPACING:** 4"
- ASSEMBLY:** Riveted and/or welded for maximum service; Full jambs with blades, head and sill contained within
- FINISH:** Mill
- SCREEN:** ½" sq. mesh 19-GA galvanized

OPTIONS

- Flange Frame
- Extended Sub-Sills (3" or 5")
- Sub-Frame
- Installation Angles
- Stainless Steel, Other Steel Gauges
- Finishes - Baked Enamel, Epoxies
- Variety of Bird and Insect Screens
- Blank-Off Panels

NOTES

1. "A" width and "B" height are opening dimensions. Louvers are provided approximately ½" undersize.
2. Approximate louver weight is 11 lbs./sq.ft.

LOUVER SIZE

Panels	Minimum Panel	Maximum Panel
SL67	12"W x 12"H	60"W x 96"H

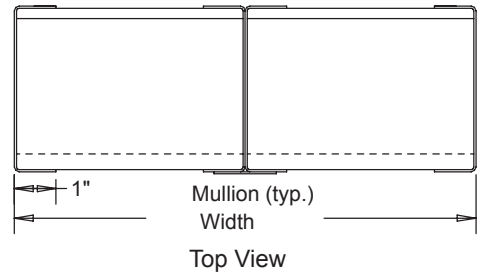
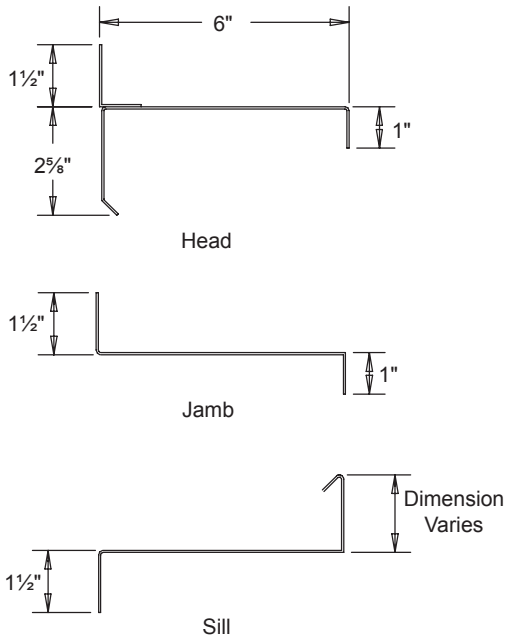
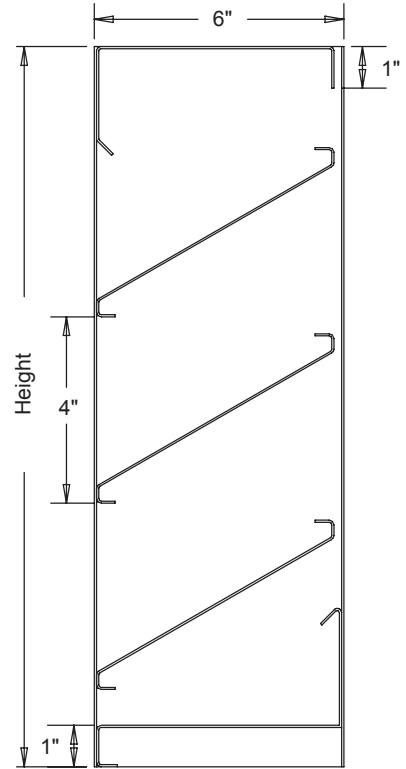

This page intentionally left blank.