

Roof Curb

Self-Flashing • Insulated • Aluminum or Steel Curb

STANDARD CONSTRUCTION

Formed Aluminum Curb

SHELL & .063" thick aluminum alloy 3003-H14; All seams

BASE PLATE: are fully welded and sprayed with protective coating

INSULATION: 1" semi-rigid fiberglass

NAILER: Nominal 2" x 2" wood nailer for equipment mounting is mechanically fastened to upper curb perimeter

FINISH: Mill

Formed Steel Curb

SHELL & 18-GA galvanized steel; All seams are fully

BASE PLATE: welded and sprayed with protective coating

INSULATION: 1" semi-rigid fiberglass

NAILER: Nominal 2" x 2" wood nailer for equipment mounting is mechanically fastened to upper curb perimeter

FINISH: Mill

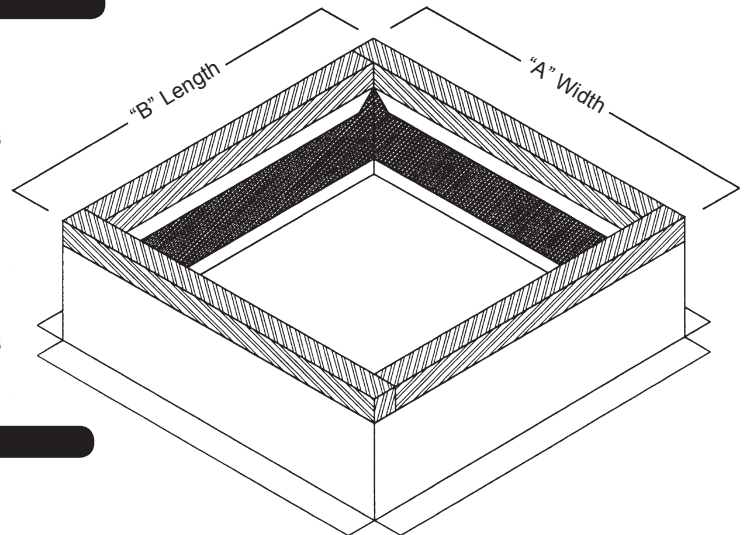

OPTIONS

Material Aluminum - Available in .081-.125 thick 3003-H14 alloy.

Material Steel - Available in various gauges of galvanized, galvaneal or stainless.

Pitched or Peaked - In conjunction with the overall dimensions, both the height rise, specified in linear inches per foot (ex: 3" in 12") and the direction of the pitch must be specified.

Liners - Used for retention of insulation or as support to strengthen large units that will support a heavy load. Liners are manufactured as an integral part of the product to add maximum structural support.

Corners - Solid welded corners may be added to the self flashing flange on the bottom of the curb.

Platform Cap - A 3/4" plywood top with a metal cap fabricated of the same material as the product.

Gasket - 1/4" thick polyurethane foam gasket can be installed, lining the entire top perimeter. Gasket can be used in place of, or in addition to a wood nailer.

Insulation - Available with 2" semi-rigid insulation.

Access Panels - To provide a passageway to internal equipment, an access opening is cut and lined with a protective vinyl edge seal and the cover panel is mechanically fastened over the opening. Minimum height restrictions apply.

Louvered Vents - Provides airflow through the curb. Units are available with 6"W x 7/8"H louvered vents, with 4 per side. Minimum height restrictions apply.

Damper Rack - The rack is located in the bottom of the curb and a damper is then mounted on top of the rack. Damper and/or rack flange dimensions must be specified.

Security Bars - Selections of bar diameters, frame styles, and spacing are available.

Finishes - A wide selection of finishes include baked enamel, epoxy, or prime coat. Aluminum curb finishes include Kynar, clear or color anodize.

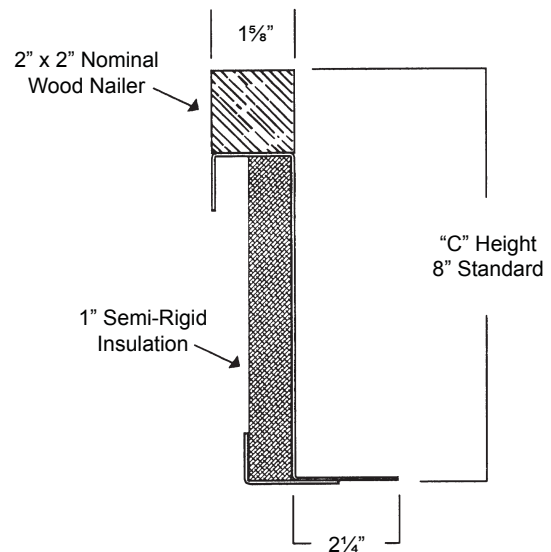

NOTES

1. "A" width, "B" length and "C" height are outside dimensions.
2. If either dimension exceeds 90", multi-section construction may be required.
3. Standard curb has no corners.

This page intentionally left blank.