

# EQUIPMENT SUPPORT

# A-ESC

## STANDARD CONSTRUCTION

Standard Cant  
Formed Aluminum

- Fabricated of .063" thick aluminum alloy 3003-H14 shell and base plate. All seams are fully welded and sprayed with protective coating.
- Incorporates a mitered 3" x 3" Integral Cant.
- Internal reinforcements at 12" centers.
- Factory installed Wood Nailer for equipment mounting is mechanically fastened.
- Mill finish is standard.
- Lengths exceeding 90" may require multiple section construction.

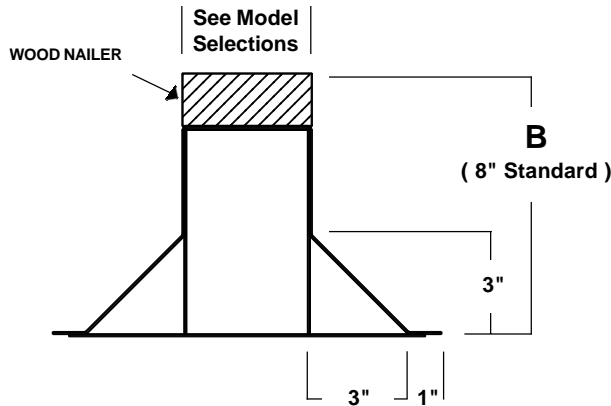
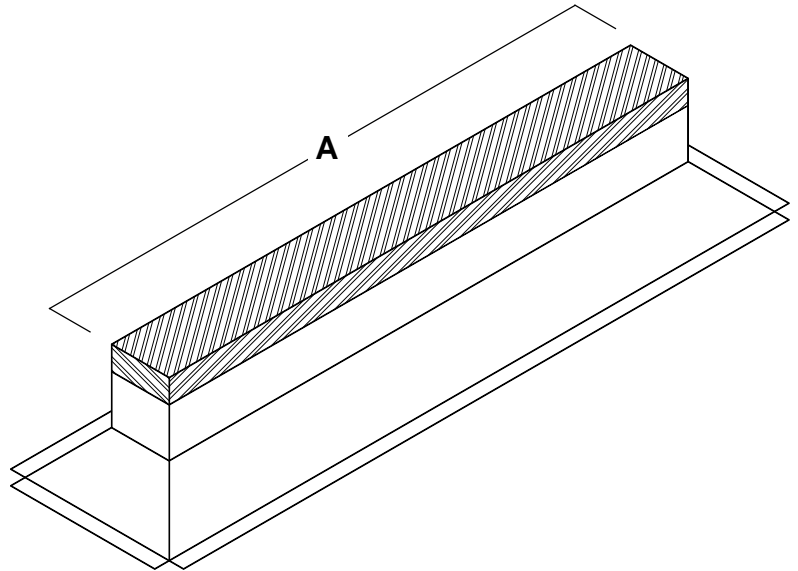

## MODEL SELECTIONS

|          | NOMINAL WIDTH | ACTUAL NAILER WIDTH |
|----------|---------------|---------------------|
| A-ESC-04 | 4"            | 3 1/2"              |
| A-ESC-06 | 6"            | 5 1/2"              |
| A-ESC-08 | 8"            | 7 1/2"              |
| A-ESC-10 | 10"           | 9 1/2"              |
| A-ESC-12 | 12"           | 11 1/2"             |

| 'A' (width) | 'B' (height) | Qty | Options / Accessories / Variations |
|-------------|--------------|-----|------------------------------------|
|             |              |     |                                    |
|             |              |     |                                    |
|             |              |     |                                    |
|             |              |     |                                    |
|             |              |     |                                    |

PROJECT \_\_\_\_\_ LOCATION \_\_\_\_\_  
 ARCH/ENGR \_\_\_\_\_ CONTRACTOR \_\_\_\_\_  
 REPRESENTATIVE \_\_\_\_\_ DATE \_\_\_\_\_

PC00113 - April 2000

ROOF CURBS

# LD Louvers & Dampers

A DIVISION OF MESTEK, INC.

P.O. Box 606 • 7435 Industrial Rd • Florence, KY 41042 • Phone (859) 647-2299 • Fax (859) 647-7810

## OPTIONS / ACCESSORIES

### MATERIAL

Aluminum products are also available in either .081" or .125" thick 3003-H14 alloy.

### PITCHED OR PEAKED

All units are available as pitched or peaked. In conjunction with the overall unit dimensions, both the height rise, specified in inches per linear foot ( e.g. 3" in 12" ) and the direction of the pitch must be specified.

### COUNTERFLASHING

A removable metal cap fabricated of the same material as the equipment support provides for an effective method of attaching roofing felts.

### GASKET

1/4" thick polyurethane foam gasket can be installed, lining the entire top perimeter. Gasket can be used in place of, or in addition to a wood nailer.

### FINISHES

A wide selection of finishes including Baked Enamel, Epoxy, Kynar, Clear or Color Anodize, or Prime Coat.