

# EQUIPMENT SUPPORT

# A-ESF

Self Flashing  
Formed Aluminum

## STANDARD CONSTRUCTION

- Fabricated of .063" thick aluminum alloy 3003-H14 shell and base plate. All seams are fully welded and sprayed with protective coating.
- Internal reinforcements at 12" centers.
- Factory installed Wood Nailer for equipment mounting is mechanically fastened.
- Mill finish is standard.
- Lengths exceeding 90" may require multiple section construction.

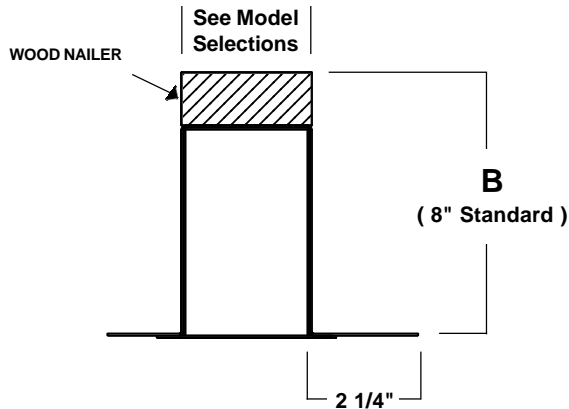
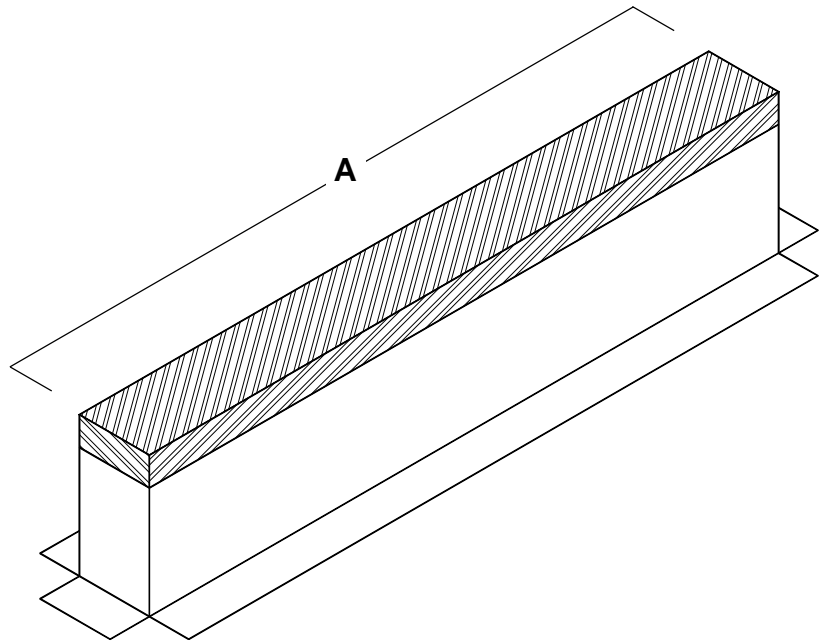

## MODEL SELECTIONS

	NOMINAL WIDTH	ACTUAL NAILER WIDTH
A-ESF-04	4"	3 1/2"
A-ESF-06	6"	5 1/2"
A-ESF-08	8"	7 1/2"
A-ESF-10	10"	9 1/2"
A-ESF-12	12"	11 1/2"

'A' (width)	'B' (height)	Qty	Options / Accessories / Variations

PROJECT _____	LOCATION _____
ARCH/ENGR _____	CONTRACTOR _____
REPRESENTATIVE _____	DATE _____

PC00117 - April 2000

ROOF CURBS

# LD Louvers & Dampers

A DIVISION OF MESTEK, INC.

P.O. Box 606 • 7435 Industrial Rd • Florence, KY 41042 • Phone (859) 647-2299 • Fax (859) 647-7810

# A-ESF

## OPTIONS / ACCESSORIES

### MATERIAL

Aluminum products are also available in either .081" or .125" thick 3003-H14 alloy.

### PITCHED OR PEAKED

All units are available as pitched or peaked. In conjunction with the overall unit dimensions, both the height rise, specified in inches per linear foot ( e.g. 3" in 12" ) and the direction of the pitch must be specified.

### COUNTERFLASHING

A removable metal cap fabricated of the same material as the equipment support provides for an effective method of attaching roofing felts.

### CORNERS

Solid welded corners may be added to the self flashing flange on the bottom.

### GASKET

1/4" thick polyurethane foam gasket can be installed, lining the entire top perimeter. Gasket can be used in place of, or in addition to a wood nailer.

### FINISHES

A wide selection of finishes including Baked Enamel, Epoxy, Kynar, Clear or Color Anodize, or Prime Coat.