

Roof Curb



Raised Cant Equipment Support • Aluminum or Steel

STANDARD CONSTRUCTION

Formed Aluminum Curb

- SHELL &** .063" thick aluminum alloy 3003-H14; All seams
- BASE PLATE:** are fully welded and sprayed with protective coating
- INSULATION:** 1" semi-rigid fiberglass
- CANT:** Mitered 3" x 3" integral cant
- REINFORCEMENTS:** On 12" centers
- NAILER:** Varies by width, factory installed
- FINISH:** Mill

Formed Steel Curb

- SHELL &** 18-GA galvanized steel; All seams are fully
- BASE PLATE:** welded and sprayed with protective coating
- INSULATION:** 1" semi-rigid fiberglass
- CANT:** Mitered 3" x 3" integral cant
- REINFORCEMENTS:** On 12" centers
- NAILER:** Varies by width, factory installed
- FINISH:** Mill

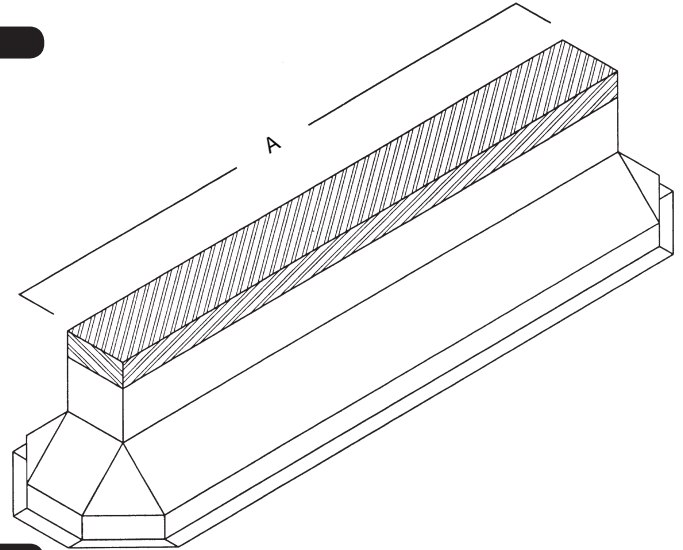

OPTIONS

- Material Aluminum** - Available in .081-.125 thick 3003-H14 alloy
- Material Steel** - Available in various gauges of galvanized, galvaneal or stainless
- Pitched or Peaked** - In conjunction with the overall dimensions, both the height rise, specified in linear inches per foot (ex: 3" in 12") and the direction of the pitch must be specified.
- Counterflashing** - A removable metal cap fabricated of the same material as the equipment support provides for an effective method of attaching roofing felts.
- Gasket** - ¼" thick polyurethane foam gasket can be installed, lining the entire top perimeter. Gasket can be used in place of, or in addition to a wood nailer.
- Finishes** - A wide selection of finishes include baked enamel, epoxy, or prime coat. Aluminum curb finishes include Kynar, clear or color anodize.

NOTES

1. "A" and "B" are opening dimensions.
2. If either dimension exceeds 90", multi-section construction may be required.

EQUIPMENT SUPPORT WIDTH

Nominal Width	Actual Nailer Width
4"	3½"
6"	5½"
8"	7½"
10"	9½"
12"	11½"

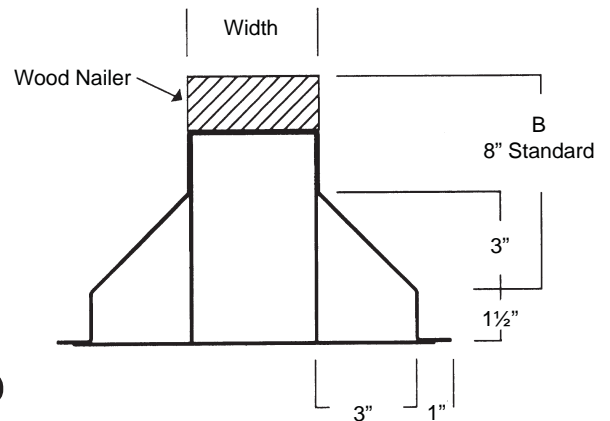

This page intentionally left blank.