

Smoke Damper

KA1

Leakage Class I • Temperature 250°F or 350°F • Galvanized Steel • Airfoil Blade

STANDARD CONSTRUCTION

- FRAME:** 5½" x 7/8" x 16-GA galvanized steel hat channel; A flat head and sill are used for sizes thru 13" high
- BLADES:** 20-GA galvanized steel double skinned (equal to 14-GA); Parallel action
- AXLES:** Plated solid steel stub
- BEARINGS:** Oil impregnated bronze
- LINKAGE:** Plated steel angle and crank plates with stainless steel pivots; In-jamb type
- STOPS:** 18-GA galvanized steel at head and sill
- BLADE SEALS:** Silicone
- JAMB SEALS:** Stainless steel
- SLEEVE:** Minimum 20-GA galvanized steel by 18" long (sizes greater than 84" wide or 84" high require minimum 18-GA)
- CAULKING:** Hardcast Irongrip 601 or UL-listed equivalent
- FINISH:** Mill on galvanized steel
- ACTUATOR:** Electric or pneumatic; Factory-installed for Power-Open/Spring-Close (fail close) operation; External left hand mounted as viewed from jackshaft side of damper

OPTIONS

- Right hand and/or internal actuator mounting locations (restrictions apply)
- Integral Dual Position Indication (IDPI) switches
- Model SM-501 Flow-rated smoke detector (10" minimum damper height)
- Model 2151 No-flow smoke detector (12" minimum damper height)
- Tab-Lock retaining angles
- Stainless steel bearings
- Copper tubing (for pneumatic actuators)
- Sleeves of various depths and gauge thicknesses
- No sleeve or sideplate only (restrictions apply)
- Round or oval transitions
- Short-width (<12") and/or short-height (<8") transitions

NOTES

1. Damper frames are provided approximately ¼" undersized. The addition of a sleeve will increase the size of the assembly.
2. Damper with smoke detector must have a minimum sleeve of 19" (10.5" on the actuator side and 3" on the non-actuator side).

DAMPER SIZES

Orientation	Horizontal & Vertical		
	Min Panel	Max Panel	Max Assy
Rectangular	4"Wx4"H (12"Wx8"H frame)	36"Wx48"H	144"Wx96"H or 288"Wx48"H
Round	4" dia. (12"Wx8"H frame)	34" dia.	60" dia.
Oval	4"Wx4"H (12"Wx8"H frame)	34"Wx46"H	106"Wx60"H

*Dampers smaller than minimum frame size require a transition. Reference SD-TRFS.

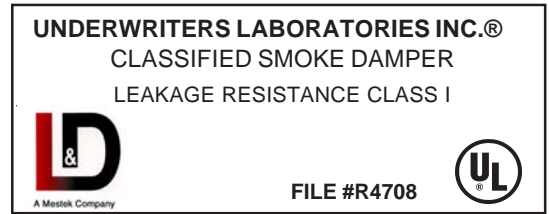

This smoke damper meets the construction and performance requirements of:

- Underwriters Laboratories Inc. Standard 555S
- National Fire Protection Association Standards 90A, 92A, and 92B
- ICC's International Building Code
- ICBO's Uniform Building Code
- SBCCI's Standard Building Code
- BOCA's National Building Code
- California State Fire Marshal Listing #3230-1328:111
- Underwriters Laboratories Inc. Approved for dual direction airflow and dynamic conditions.
- Underwriters Laboratories Inc. Classified for use in smoke control systems for Leakage Class I and 250°F or 350°F.
- Actuators must be controlled by a smoke detection system.

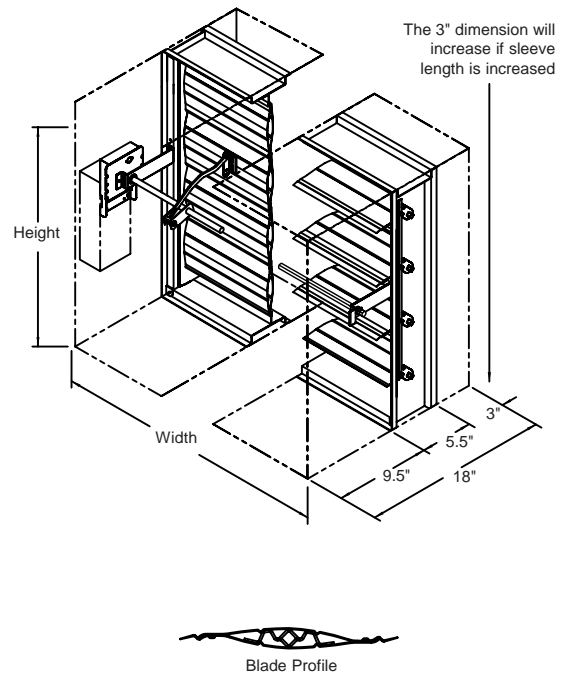

Operations Ratings:

Maximum Differential Pressure: 4 in. wg

Maximum Velocity: 2000 fpm (3000 fpm for selected size/actuator combinations)

Leakage Ratings:

UL Class I

4 cfm per sq. ft. maximum @ 1 in. wg

8 cfm per sq. ft. maximum @ 4 in. wg

Sound Ratings:

None Available

Pressure Drop Ratings:

The pressure drop data shown below is based on laboratory conditions. The test setup does not take into account elbows or other duct fittings that are part of every actual duct system. The configuration of the actual duct system immediately upstream and downstream of the damper often contributes more pressure loss than the damper itself.

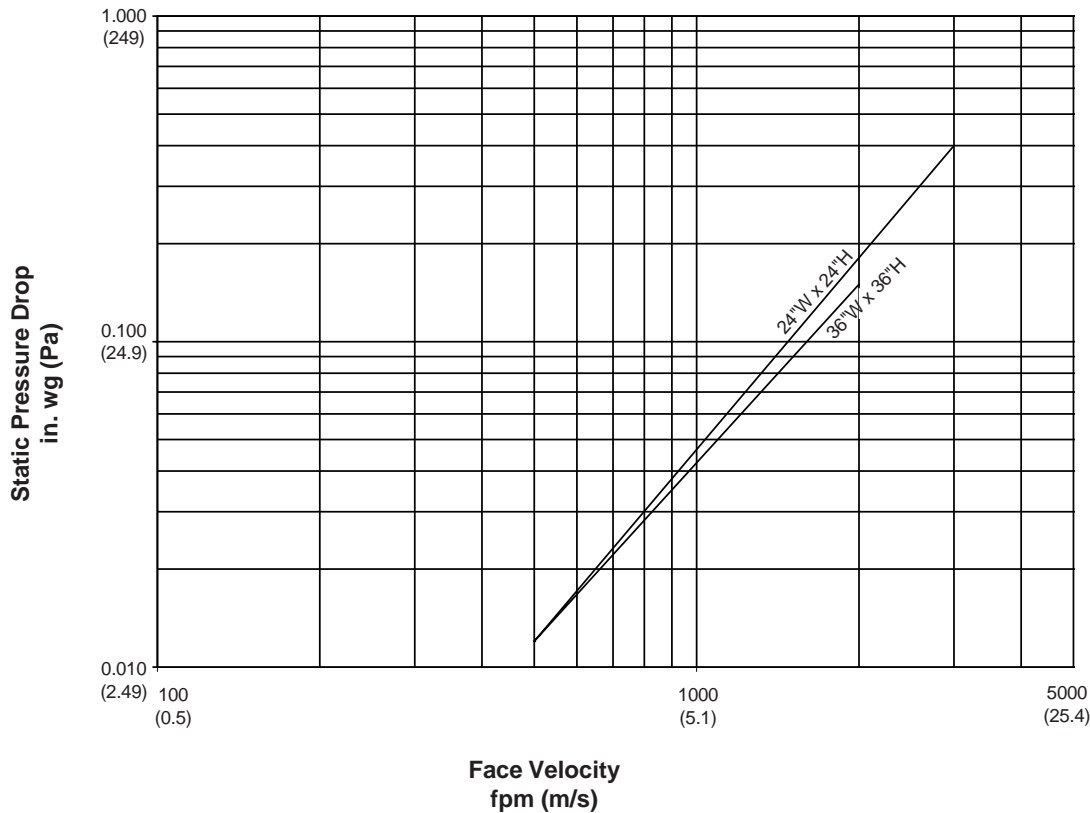

This product was tested in accordance with AMCA Standard 500D.

AMCA Figure 5.3