

Smoke Damper

KA2

Leakage Class II • Airfoil Blade • 250°F or 350°F • UL Classified Smoke Damper

STANDARD CONSTRUCTION

- FRAME:** 5½" x 7⁄8" x 16-GA galvanized steel hat channel
- BLADES:** 20-GA galvanized steel double skinned (equal to 14-GA); Parallel action
- AXLES:** Plated solid steel stub
- BEARINGS:** Oil impregnated bronze
- LINKAGE:** Plated steel angle and crank plates with stainless steel pivots; In-jamb type
- STOPS:** 18-GA galvanized steel at head and sill
- BLADE SEALS:** Silicone
- JAMB SEALS:** Stainless steel
- SLEEVE:** Minimum 20-GA galvanized steel by 18" long (sizes greater than 84" wide or 84" high require minimum 18-GA)
- CAULKING:** Hardcast Irongrip 601 or UL-listed equivalent
- FINISH:** Mill on galvanized steel
- ACTUATOR:** Electric or pneumatic; Factory-installed for Power-Open/Spring-Close (fail close) operation; External left hand mounted as viewed from jackshaft side of damper

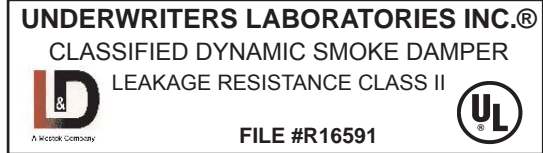

This smoke damper meets the construction and performance requirements of:

- Underwriters Laboratories Inc. Standards 555 and 555S
- National Fire Protection Association Standards 80 and 90A
- ICC's International Building Code
- New York City MEA Listing #111-99-M
- California State Fire Marshal Listing #3225-1328:111
- Underwriters Laboratories Inc. Approved for dual direction airflow and dynamic conditions.
- Underwriters Laboratories Inc. Classified for use in smoke control systems for Leakage Class II and 250°F or 350°F.
- Actuators must be controlled by a smoke detection system.

OPTIONS

- Exact Size
- Sleeve - Transitions - Sideplate
- Flange - Front, Rear or Both
- Actuators - 120V, 24V, 230V or Pneumatic
- Right Hand and/or Internal Actuator Mounting Locations (Restrictions Apply)
- Power-Close/Spring Open
- Integral Dual Position Indication (IDPI) Switches
- Model SM-501 Flow-Rated Smoke Detector (10" Minimum Damper Height)
- Model 2151 No-Flow Smoke Detector (12" Minimum Damper Height)
- Remote Test Box
- Copper Tubing (For Pneumatic Actuators)
- Transformers
- Tab-Lock Retaining Angles - 1 or 2 sets
- Bearings - OIB or Stainless Steel
- Axle - Stainless Steel
- Security Bars
- Short-Width (<8") and/or Short-Height (<8") Transitions

NOTES

1. Damper frames are provided approximately ¼" undersized. The addition of a sleeve will increase the size of the assembly.
2. Damper with smoke detector must have a minimum sleeve of 19" (10.5" on the actuator side of 3" on the non-actuator side).

DAMPER SIZE

		2000 fpm, 4 in.wg		4000 fpm, 6 in.wg, 250°F Only	
Orientation	Hor & Vert	Horizontal & Vertical		Horizontal & Vertical	
Panel	Min Panel	Max Panel	Max Assy	Max Panel	Max Assy
Rectangular	4"W x 4"H (8"W x 8"H frame)	36"W x 48"H	144"W x 96"H 288"W x 48"H	24"W x 24"H	96"W x 24"H
Round	4" dia. (8"W x 8"H frame)	34" dia.	60" dia.	22" dia.	n/a
Oval	4"W x 4"H (8"W x 8"H frame)	34"W x 46"H	106"W x 60"H	22"W x 22"H	94"W x 22"H

*Dampers smaller than minimum frame size require a transition. Reference SD-TRFS.

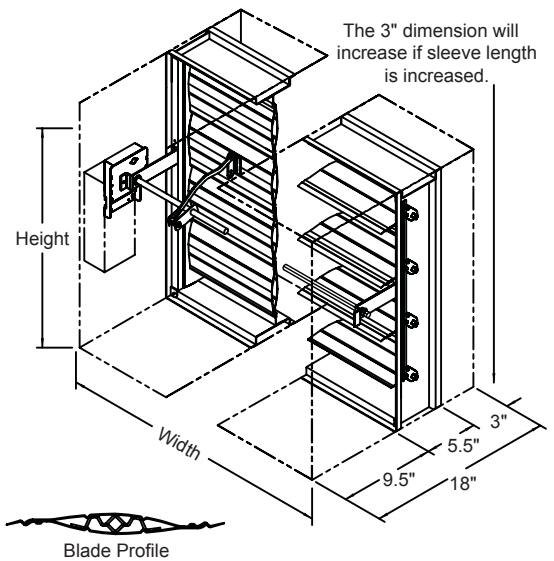

Operations Ratings:

Maximum Differential Pressure: 4 in. wg (6 in.wg for selected size/actuator combinations)
 Maximum Velocity: 2000 fpm (4000 fpm for selected size/actuator combinations)

Leakage Ratings:

UL Class II
 10 cfm per sq. ft. maximum @ 1 in. wg
 20 cfm per sq. ft. maximum @ 4 in. wg
 24.5 cfm per sq.ft. maximum @ 6 in. wg

Sound Ratings:

None Available

Pressure Drop Ratings:

The Pressure drop data shown below is based on laboratory conditions. The test setup does not take into account elbows or other duct fittings that are part of every actual duct system. The configuration of the actual duct system immediately upstream and downstream of the damper often contributes more pressure loss than the damper itself.

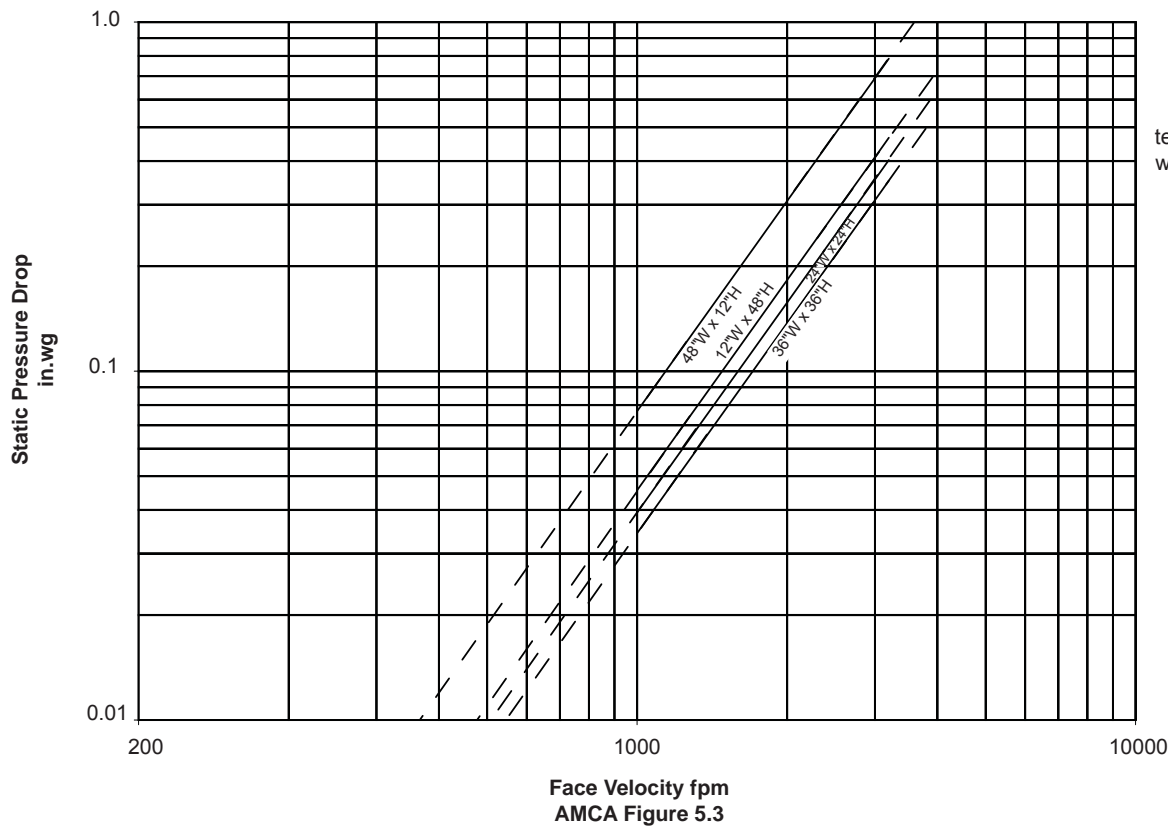

This product was tested in accordance with AMCA Standard 500D.