

# Smoke Damper



# KR1

Class I • 250°F or 350°F • Galvanized Steel • Single Thickness Blade • UL Classified Damper

## STANDARD CONSTRUCTION

- FRAME:** 20-GA galvanized steel flat by 18" long integral sleeve
- BLADES:** 16-GA galvanized steel single thickness; Parallel action
- AXLES:** Plated solid steel stub
- BEARINGS:** Oil impregnated bronze
- LINKAGE:** Galvanized steel angle interconnect, with plated steel brackets and pivots located on blade
- STOPS:** 18-GA galvanized steel at head and sill
- BLADE SEALS:** Silicone
- JAMB SEALS:** Stainless steel
- SLEEVE:** Integral 20-GA galvanized steel by 18" long
- RETAINING ANGLES:** 7/8" x 1 1/2" x 16-GA adjustable perimeter mounting angle for dampers > 10"W x 10"H; dampers ≤ 10"W x 10"H retaining angles shipped loose
- CAULKING:** Hardcast Irongrip 601 or UL-listed equivalent
- FINISH:** Mill on galvanized steel
- ACTUATOR:** Electric with heat response device (EHRD) or pneumatic with heat response device (PHRD); Factory-installed for Power-Open/Spring-Close (fail close) operation; External left hand mounted as viewed from jackshaft side of damper

**UNDERWRITERS LABORATORIES INC.®**  
**CLASSIFIED SMOKE DAMPER**  
**LEAKAGE RESISTANCE CLASS I**

**FILE #R4708**

This combination fire/smoke damper meets the construction and performance requirements of:

- Underwriters Laboratories Inc. Standards 555 and 555S
- National Fire Protection Association Standards 90A, 92A, and 92B
- ICC's International Building Code
- California State Fire Marshal Listing #3225-1328:120
- Underwriters Laboratories Inc. Approved for dual direction airflow and dynamic conditions.
- Underwriters Laboratories Inc. Classified for use in smoke control systems for Leakage Class I and 250°F or 350°F.
- Actuators must be arranged to operate automatically, must fail closed upon loss of power, and must be controlled by a smoke detection system.

## OPTIONS

- Right hand actuator mounting location
- Integral Dual Position Indication (IDPI) switches
- Model SM-501 Flow-rated smoke detector (10" minimum damper height) ship loose only
- Model 2151 No-flow smoke detector (12" minimum damper height) ship loose only
- Tab-Lock retaining angles
- Stainless steel bearings
- Copper tubing (for pneumatic actuators)
- Sleeves of various depths
- Round or oval transitions
- Short-width (<6") and/or short-height (<6") transitions

## NOTES

1. "A" width and "B" height are opening dimensions. Damper frames are provided approximately 1/4" undersized.
2. Dampers are available in 1" increments only.

## LOUVER SIZE

Orientation	Horizontal & Vertical	
	Minimum Panel	Maximum Panel
Rectangular	4"W x 4"H (16"W x 6"H frame)	24"W x 24"H
Round	4" dia. (16"W x 6"H frame)	22" dia.
Oval	4"W x 4"H (16"W x 6"H frame)	22"W x 22"H

\*Dampers smaller than minimum frame size require a transition. Reference SD-TRFS.

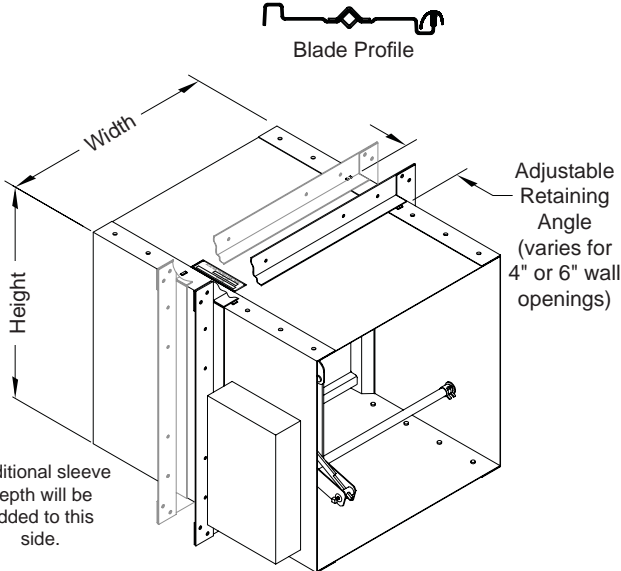

**Operations Ratings:**

Maximum Differential Pressure: 4 in. wg  
 Maximum Velocity: 2000 fpm

**Leakage Ratings:**

UL Class II  
 8 cfm per sq. ft. maximum @ 4 in. wg

**Sound Ratings:**

The Noise Criterion data below was tested in accordance with ASTM E477.99 in the center octave band.

Damper Size	Noise Criterion (NC)			
	Velocity fpm (m/s)			
	1000 (5.08)	2000 (10.16)	3000 (15.24)	4000 (20.32)
12"W x 12"H (305mm x 305mm)	22dB	44dB	55dB	62dB
24"W x 24"H (610mm x 610mm)	30dB	50dB	62dB	not available

**Pressure Drop Ratings:**

The pressure drop data shown below is based on laboratory conditions. The test setup does not take into account elbows or other duct fittings that are part of every actual duct system. The configuration of the actual duct system immediately upstream and downstream of the damper often contributes more pressure loss than the damper itself.

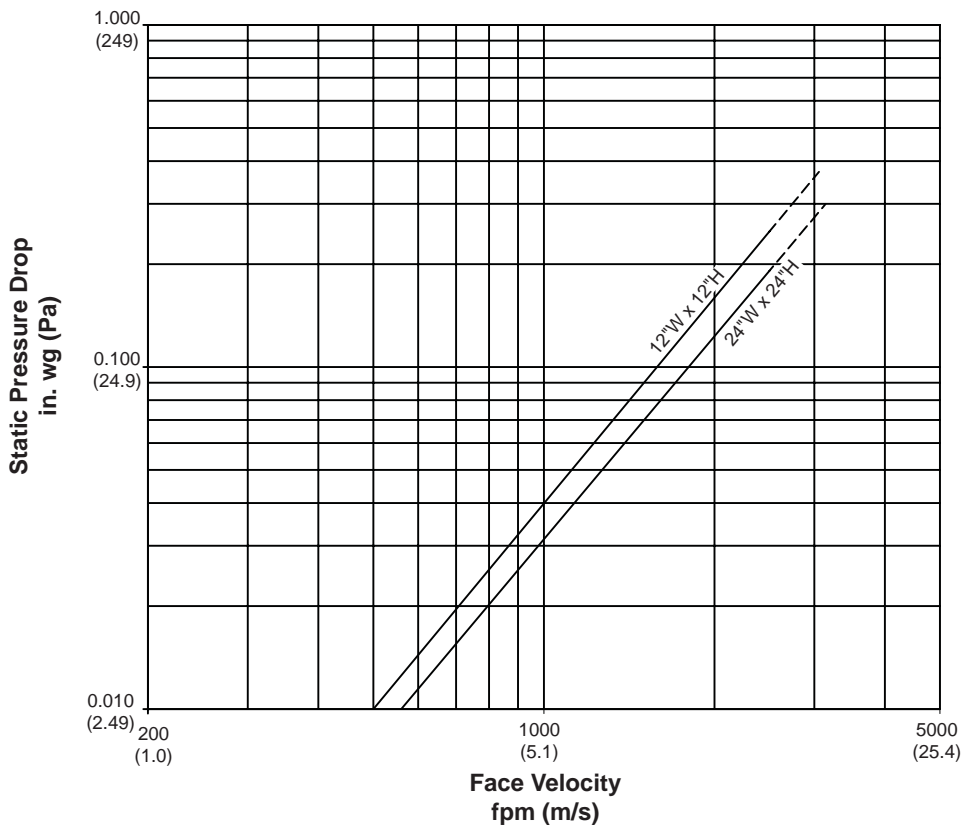

Louvers & Dampers certifies that the model KR1 damper shown here is licensed to bear the AMCA seal. The ratings shown are based on tests and procedures performed in accordance with AMCA Publication 511 and comply with the requirements of the AMCA Certified Ratings Program. The AMCA Certified Ratings Seal applies to Air Performance Ratings only.