

VOLUME CONTROL BALANCING DAMPER, SINGLE THICKNESS BLADE, GALVANIZED STEEL, 1" W.G., 1500 F.P.M.

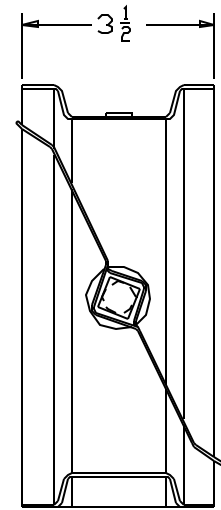
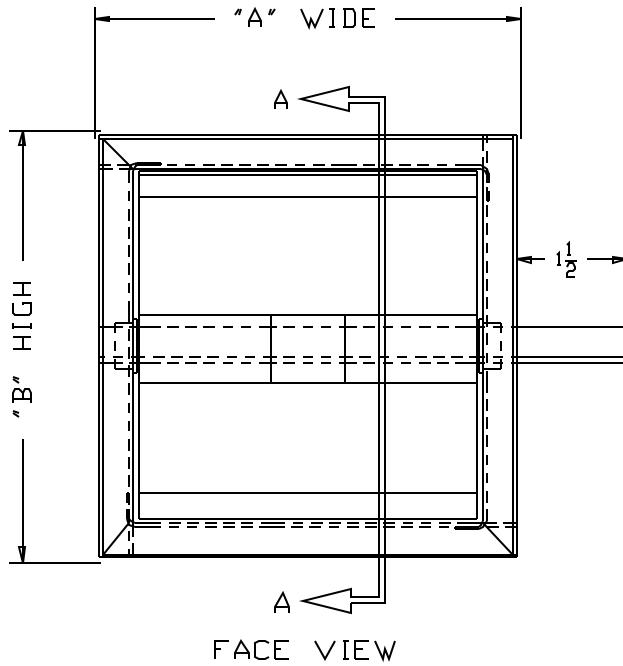

L & D ITEM NO.	QUANTITY	"A" WIDE	"B" HIGH	OPTIONS			COMMENTS
				ALUMINUM FRAME AND BLADE WITH STAINLESS STEEL AXLES	POLYDAN FRAME STUBS	304 STAINLESS STEEL	

L-11 STANDARD SPECIFICATIONS

- FRAME: 3-1/2" X 5/8 X 16 GAUGE GALVANIZED STEEL HAT CHANNEL.
 BLADE: 20 GAUGE GALVANIZED STEEL. SINGLE THICKNESS.
 AXLES: 3/8" SQUARE PLATED STEEL STUB, WITH LANDED RETAINERS.
 BEARINGS: NYLON
 FINISH: MILL.
 ACTUATOR: 3/8" SQUARE MANUAL LOCKING QUADRANT, SHIPPED LOOSE.

NOTES

- ANY VARIATIONS TO THE STANDARD SPECIFICATIONS MUST BE FACTORY APPROVED IN ADVANCE.
- MINIMUM PANEL SIZE: 6" V X 4" H.
 MAXIMUM PANEL SIZE: 36" V X 12" H.
 DAMPER CAN ONLY BE ORDERED IN 1" INCREMENTS.
- DIMENSIONS: "A" (WIDTH) AND "B" (HEIGHT) DIMENSIONS ARE OPENING SIZES. DAMPER WILL BE FABRICATED 1/4" UNDERSIZED.
- THIS MODEL IS NOT RECOMMENDED FOR MOTORIZED APPLICATIONS.
- UNIT HAS ONLY ONE BLADE AND WILL EXTEND INTO THE AIRSTREAM IN MOST CASES.
- UNITS MAY BE MOUNTED VERTICALLY OR HORIZONTALLY

REV.	DESCRIPTION	DATE	BY
DATE :			
L & D PROD. No. :			
PROJECT :			
CUSTOMER / ORDER No. :			
ARCH. / ENGR. :			
AGENT / ORDER No. :			
 LOUVERS & DAMPERS A MESTEK COMPANY 7435 INDUSTRIAL ROAD FLORENCE, KY Phone (859) 647-2299 Fax (859) 647-7810			
L-11 RECTANGULAR DAMPER			
DRN. BY	SJA	DWG. NO.	REV.
DATE	2 12 01	L-11-1	