

# Supplemental Information

## Control Damper Panel & Jackshaft Arrangements

### Volume Control Damper Models: GD1, GD2, GD26, GD27, A28, A29, A38, A39

1. Panel and jackshaft arrangements are produced for assembly sizes through 240"W x 144"H. For larger sizes, unequal section sizes, or other special arrangements, consult the factory.
2. Assemblies that are both multiple panels wide and multiple panels high require additional structural support. Structural supports and mounting accessories are not factory supplied.
3. Damper panels that require double blade-to-blade linkage (> 30" wide) will be supplied with two jackshaft-to-drive blade linkage sets. In lieu of double drive linkage, single drive linkage can be utilized if the drive blade is reinforced with a blade stiffener.
4. Internal actuators are factory mounted and require factory supplied jackshafts. (Exception: Foot mounted Barber Colman actuators on single panel dampers do not require jackshaft.) The damper height must meet guidelines for internal mount. The jackshaft runs the full width of the damper.
5. External actuators ship loose and do not require factory supplied jackshaft. (Exception: External actuators are factory mounted and require factory supplied jackshafts on dampers ordered with a sleeve or sideplate.) If jackshaft is ordered, but actuators are field supplied, one additional drive arm per jackshaft run will be factory supplied.
  - If jackshaft and actuators are factory supplied, the jackshafts will extend beyond the dampers as follows:
    - A. 10" for #6 Siemens pneumatic actuator.
    - B. 6" for all other standard actuators.
  - If jackshaft is factory supplied, but actuators are field supplied, the jackshaft will extend beyond the damper 10".
6. Single panel dampers ordered without jackshaft will be supplied with one extended shaft kit. Double panel wide by single panel high dampers ordered without jackshaft will be supplied with two extended shaft kits. Single panel wide by double panel high dampers ordered without jackshaft will be supplied with two extended shaft kits. Double panel wide by double panel high dampers ordered without jackshaft will be supplied with four extended shaft kits. Multiple panel dampers without jackshaft are not interconnected.
7. Damper assemblies with multiple factory supplied actuators are not wired together.
8. Damper assemblies that exceed maximum single ship section limitations will ship in sections and are provided with splicing materials. Reference page 6 for splicing instructions.
9. Multiple panel disassembly is available if individual panel shipment or ship loose jackshaft is required.

#### PANELS & JACKSHAFT

Models	Maximum Panel
GD1/GD2	48"W X 72"H
GD26/GD27	48"W X 72"H
A28/A29	60"W X 72"H
A38/A39	60"W X 72"H

#### Assembled Ship Section Maximums

48 sq. ft.  
108" wide  
96" high

\*Assemblies > 48 sq.ft. will be split in height before width.

1/2" Jackshaft Maximum "Per Run"	
With Seals	16 sq.ft.
Without Seals	24 sq.ft.
Width	96"

#### EXAMPLES

##### Example #1

80"W x 30"H

1. 2 panels wide x 1 panel high
2.  $(80 \times 30) / 144 = 16.7$  square feet face area.
3. This will ship in one 2x1 section.
  - Dampers ordered without jackshaft will be provided with 2 extended shaft kits.
  - Dampers ordered with jackshaft and without seals will be provided with 1/2" diameter jackshaft, since the face area is  $\leq 24$  square feet.
  - Dampers ordered with jackshaft and with seals will be provided with 1" diameter jackshaft, since the face area is  $> 16$  square feet.

##### Example #2

45"W x 125"H

1. 1 panel wide x 2 panels high
2.  $(45 \times 125) / 144 = 39.1$  square feet face area.
3. This will ship in two 1x1 sections.
  - Dampers ordered without jackshaft will be provided with two extended shaft kits.
  - Dampers ordered with jackshaft and without seals will be interconnected vertically, since the face area is  $\leq 45$  square feet. They will be provided with 1" diameter jackshaft. The interconnect arms and hardware will ship attached and interconnect rod will ship loose.
  - Dampers ordered with jackshaft and with seals will not be interconnected vertically, since the face area is  $> 35$  square feet. They will be provided with 1" diameter jackshaft, since the face area is  $> 32$  square feet.

##### Example #3

200"W x 100"H

1. 5 panels wide x 2 panels high
2.  $(200 \times 100) / 144 = 138.9$  square feet face area.
3. Dampers will ship in two 3x1 sections and two 2x1 sections.
  - Dampers ordered without jackshaft will be supplied with blade bracket on each panel for field connection.
  - Dampers ordered with jackshaft will be provided with 1" diameter jackshaft. The splice arms and hardware will ship attached.



**1 Panel Wide x 1 Panel High**

External Mount

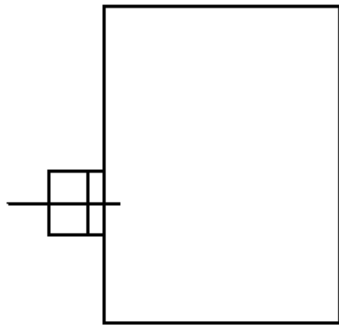

No Jackshaft Required  
1 Extended Shaft Kit

Internal Mount

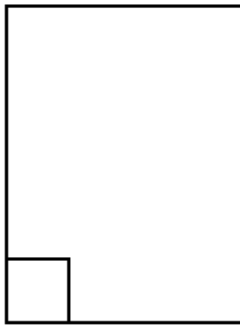

No Jackshaft Required  
Foot Mounted Barber  
Colman Actuator Only

Internal Mount

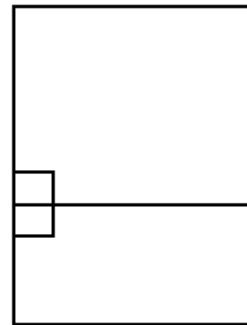

Jackshaft	1/2" dia.	1" dia.
Damper with seals	≤ 16 sq.ft.	> 16 sq.ft.
Damper w/out seals	≤ 24 sq.ft.	> 24 sq.ft.

**2 Panels Wide x 1 Panel High**

External Mount  
(Individual Operation)

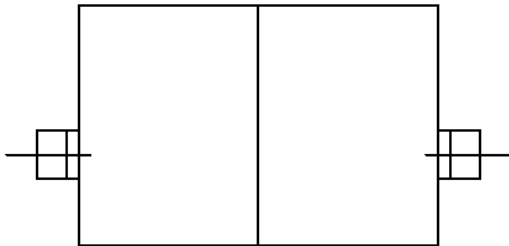

No Jackshaft Required  
2 Extended Shaft Kits

External or Internal Mount  
(Interconnected Horizontally)

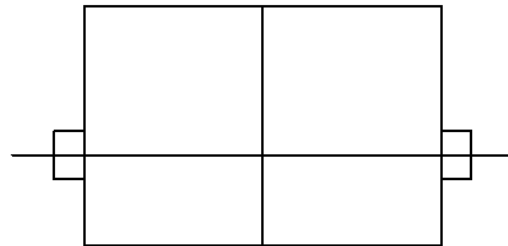

Jackshaft	1/2" dia.	1" dia.
Damper with seals	≤ 16 sq.ft.	> 16 sq.ft.
Damper w/out seals	≤ 24 sq.ft.	> 24 sq.ft.

**3 Panels Wide x 1 Panel High**

External or Internal Mount  
(Interconnected Horizontally)

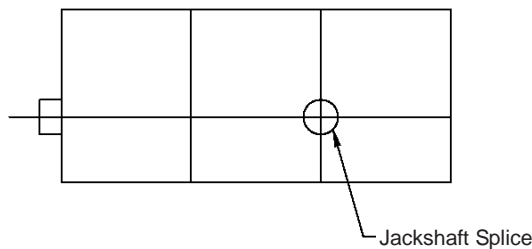

1" dia. Jackshaft

**4 Panels Wide x 1 Panel High**

External or Internal Mount  
(Interconnected Horizontally)

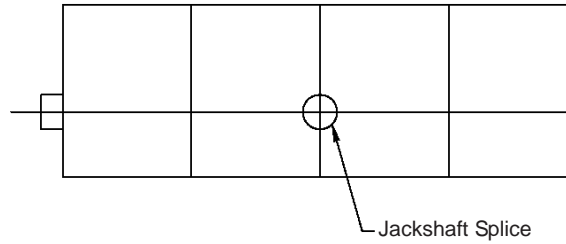

1" dia. Jackshaft

**5 Panels Wide x 1 Panel High**

External or Internal Mount  
(Interconnected Horizontally)

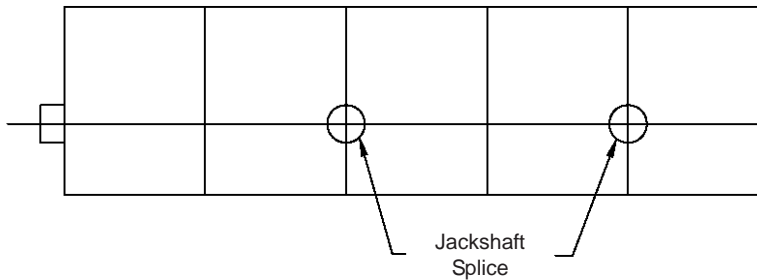

1" dia. Jackshaft

**1 Panel Wide x 2 Panels High**

External Mount  
(Individual Operation)

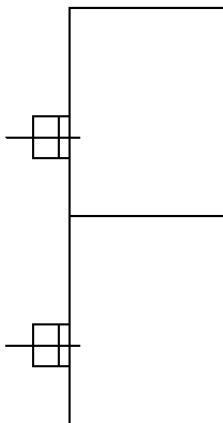

No Jackshaft Required  
2 Extended Shaft Kits

External or Internal Mount  
(Interconnected Vertically)

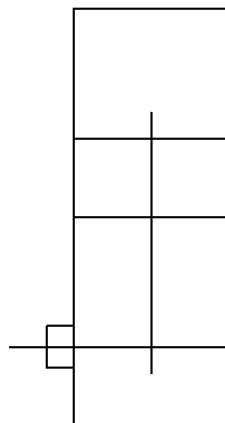

Jackshaft	1" dia.
Damper with seals	≤ 35 sq.ft.
Damper w/out seals	≤ 45 sq.ft.

Internal Mount  
(Individual Operation)

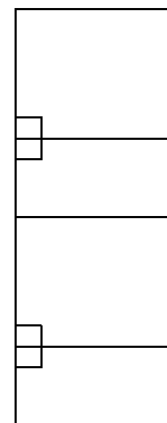

Jackshaft	1/2" dia.	1" dia.
Damper with seals	≤ 32 sq.ft.	> 32 sq.ft.
Damper w/out seals	≤ 48 sq.ft.	> 48 sq.ft.

**2 Panels Wide x 2 Panels High**

External or Internal Mount  
(Individual Operation)

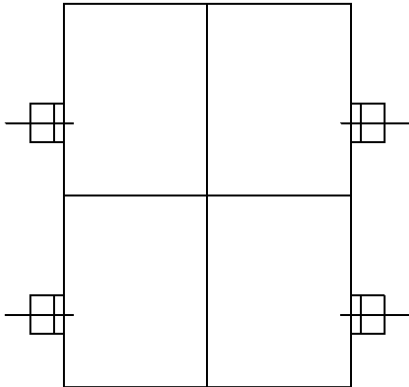

Jackshaft	1/2" dia.	1" dia.
Damper with seals	≤ 32 sq.ft.	> 32 sq.ft.
Damper w/out seals	≤ 48 sq.ft.	> 48 sq.ft.

External or Internal Mount  
(Interconnected Horizontally)

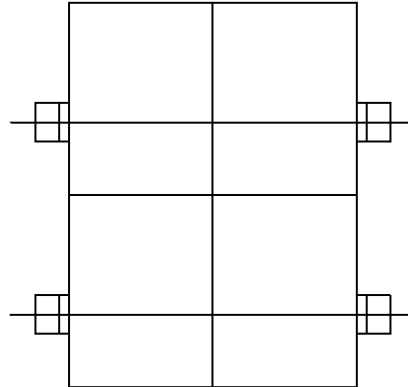

Jackshaft	1/2" dia.	1" dia.
Damper with seals	≤ 32 sq.ft.	> 32 sq.ft.
Damper w/out seals	≤ 48 sq.ft.	> 48 sq.ft.

**3 Panels Wide x 2 Panels High**

External or Internal Mount  
(Interconnected Horizontally)

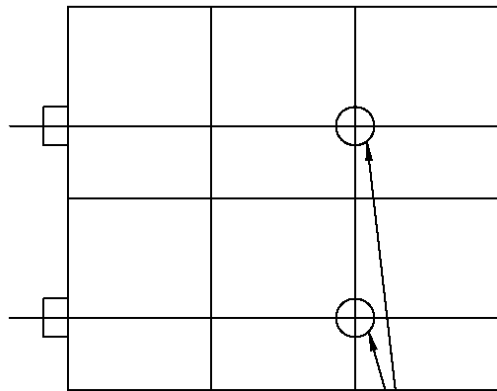

Jackshaft Splice

1" dia. Jackshaft

## 4 Panels Wide x 2 Panels High

External or Internal Mount  
(Interconnected Horizontally)

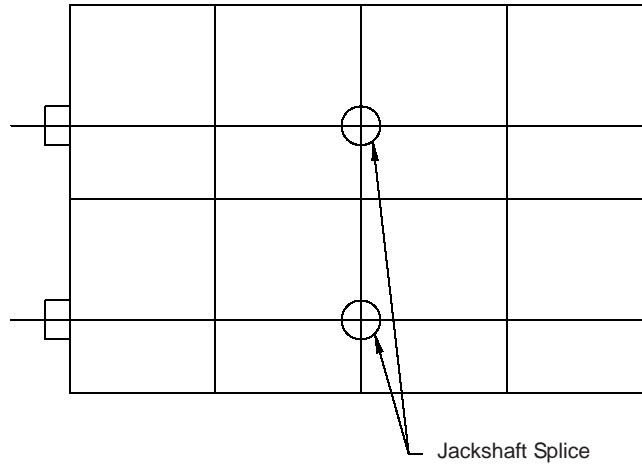

1" dia. Jackshaft

---

## 5 Panels Wide x 2 Panels High

External or Internal Mount  
(Interconnected Horizontally)

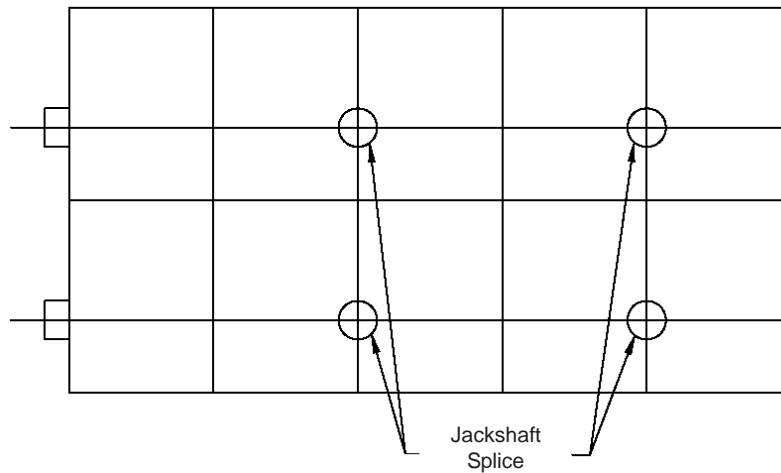

1" dia. Jackshaft

**MULTIPLE SHIP SECTION JACKSHAFT SPLICE**

1. Ensure both damper sections are in the closed position.
2. Attach the splice arms together using the nuts and bolts provided (attached to one of the splice arms).
3. If the damper sections do not close simultaneously, unclamp one splice arm on the jackshaft, adjust as required, and re-clamp.
4. Verify proper open and close operation

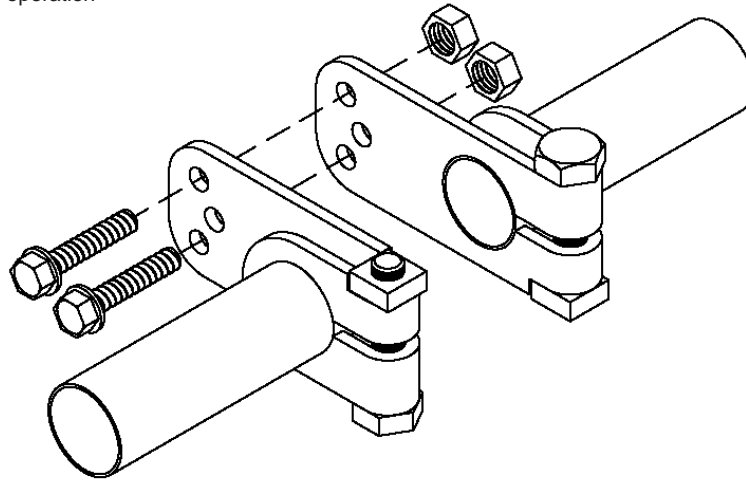
**MULTIPLE SHIP SECTION VERTICAL INTERCONNECT**

1. Slide the interconnect rod through the barrels attached to each interconnect arm.
2. Ensure both damper sections are in the closed position.
3. Clamp the barrel set screw onto the interconnect rod.
4. Verify proper open and close operation.

