

One Side Retaining Installation

Combination Fire/Smoke Damper Models: MS, CG, AS, MA, CA, UA

Fire Damper Models: MD19, MA19, 119, D19

APPLICATION

This installation instruction is to be used as a supplement to II-FS (replacing note 6 on page 2) and II-FD (replacing Note 6 on page 2). The method described by these instructions is an alternate method of mounting classified dampers within a fire barrier using perimeter retaining angles on only one side of the barrier.

NOTES

1. One side retaining angles are only available for barriers rated for less than three hours.
2. Reference Table 1 for vertical installation allowable sizes and Table 2 for horizontal installation allowable sizes.
3. The closed plane of the blades must be within the plane of the wall.
4. For horizontal installations, the actuator must be on the top side of the floor.
5. Perimeter retaining angles shall increase in size, proportionately, so there will be a minimum of 1" overlap on the wall, including at the corners.
6. The angles shall be attached to both the damper and the barrier framing on all four sides of the barrier face.
7. The leg attached to the damper can turn away from or into the opening, so long as expansion clearance is properly maintained.
8. In metal frame construction (vertical installation only), the angles can be mounted under or over the gypsum board. In wood frame construction (vertical installation only), the angles must be mounted over the gypsum board.
9. The perimeter retaining angles shall be fastened to the damper with ³/₁₆" diameter steel or stainless steel nuts and bolts or by tack welding with beads $\frac{1}{2} \pm \frac{1}{4}$ " in length or with #10 steel or stainless steel sheet metal screws or ³/₁₆" steel or stainless steel pop rivets. All connections shall be spaced on 6" maximum centers and 3" maximum from each corner (a minimum of 2 fasteners are required per side).
10. For vertical installations, perimeter retaining angles shall be fastened to the barrier on 6" maximum centers and 3" maximum from each corner (a minimum of two fasteners are required per side). For horizontal installations, perimeter retaining angles shall be fastened to the barrier on 12" maximum centers and 6" maximum from each corner (a minimum of one fastener is required per side).
 - A. In masonry construction, ³/₁₆" diameter "tapcon" or equal fasteners with a minimum of 1¹/₂" penetration are required.
 - B. In metal framed openings, fine thread drywall screws with a minimum of 1" penetration into the framing are required.
 - C. In wood framed openings, course thread drywall screws with a minimum of 1" penetration into the framing are required.
11. Perimeter retaining angles shall be a minimum of 1-¹/₂" x ⁷/₈" x 16-GA steel.
12. Corners of angles are not welded together for dampers with width or height dimensions exceeding 24". For dampers 24"W x 24"H or smaller, the corners of the perimeter mounting angles can be welded. Some local codes may not allow welded corners.
13. Perimeter retaining angles and their mounting fasteners are not typically supplied with the damper.
14. Attachment of these angles must not restrict operation of the damper.

ONE SIDE SIZE LIMITATIONS

Table 1 (Vertical Installation)

		Construction		
		Masonry	Metal Frame	Wood Frame
Model	MS1, MS2, CG1, CG2, AS1, AS2	108"Wx44"H or 44"Wx70"H	108"Wx44"H or 44"Wx70"H	36"Wx48"H or 48"Wx36"H
	MA1, MA2, CA1, CA2, UA1, UA2	108"Wx44"H or 44"Wx96"H	108"Wx44"H or 44"Wx96"H	36"Wx48"H or 48"Wx36"H
	17MD, 15MD, MD17	108"Wx44"H or 44"Wx60"H	108"Wx44"H or 44"Wx60"H	36"Wx48"H or 48"Wx36"H
	17S, 15S, 117	108"Wx44"H or 44"Wx108"H	108"Wx44"H or 44"Wx108"H	36"Wx48"H or 48"Wx36"H
	17D, 15D, D17	36"Wx36"H	36"Wx36"H	36"Wx36"H

Table 2 (Horizontal Installation)

		Construction
		Masonry
Model	MS1, MS2, CG1, CG2, AS1, AS2	36"Wx42"H
	MA1, MA2, CA1, CA2, UA1, UA2	32"Wx42"H
	17MD, 15MD, MD17	36"Wx42"H

Vertical, 1-Side Retaining, Masonry

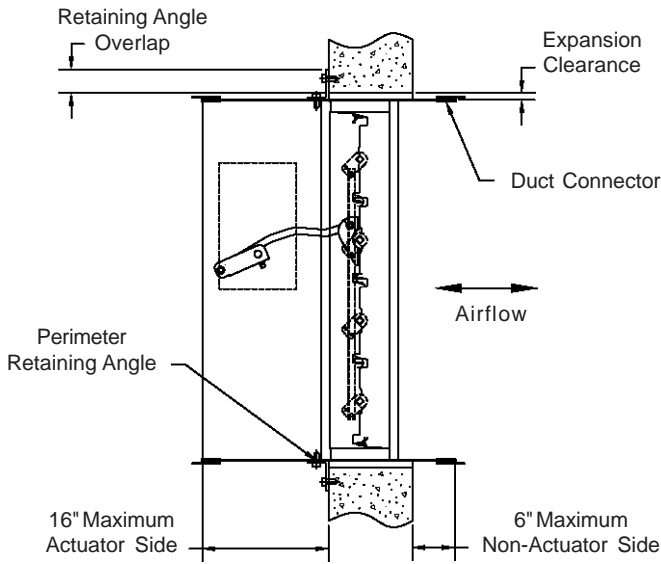

Horizontal, 1-Side Retaining, Masonry

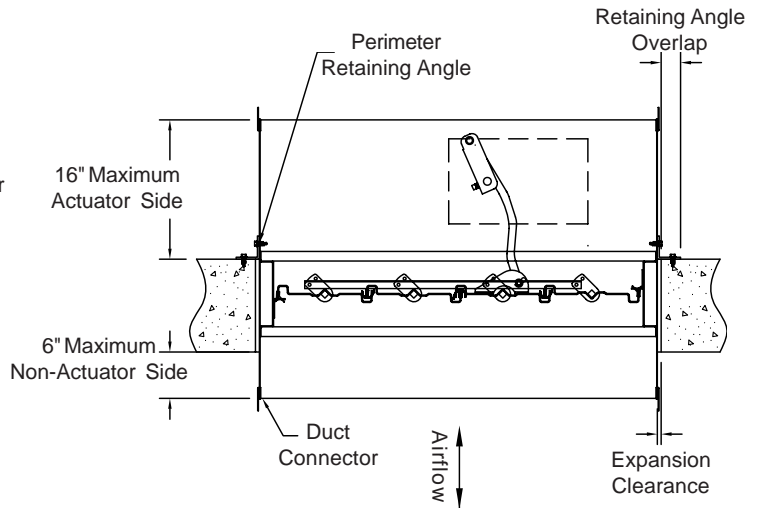

Vertical, 1-Side Retaining, Metal Stud

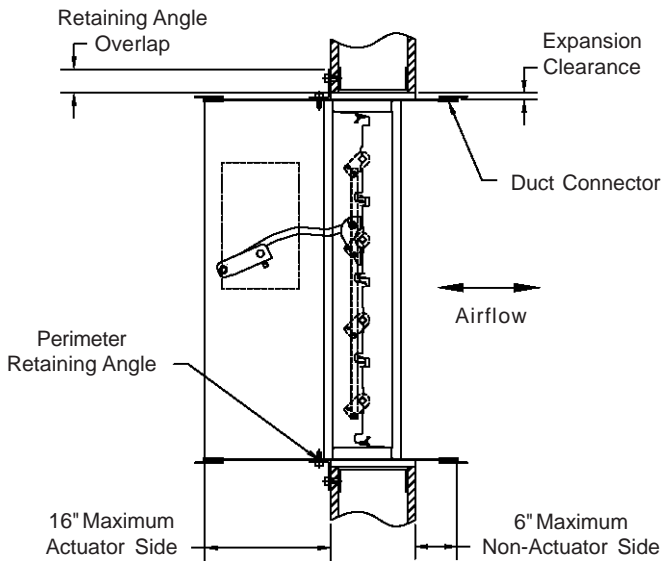

Vertical, 1-Side Retaining, Wood Stud

